

	REVISION DESCRIPTION	APP.	DRW.	DATE	CHANGE No.
△ X 3	Terminal dimension change Housing shape change Add bottom view	K.A	K.A	05/06/09	—
△ X 2	Add pin assignment	K.A	K.A	05/18/09	—
△ X					

Pin #	Description
1	DAT2
2	CD/DAT3
3	CMD
4	VDD
5	CLK
6	VSS
7	DAT0
8	DAT1

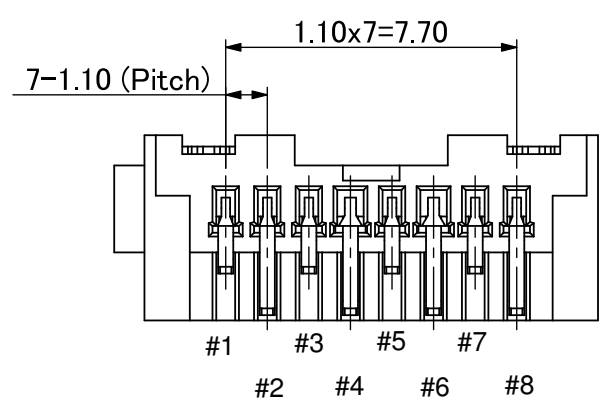
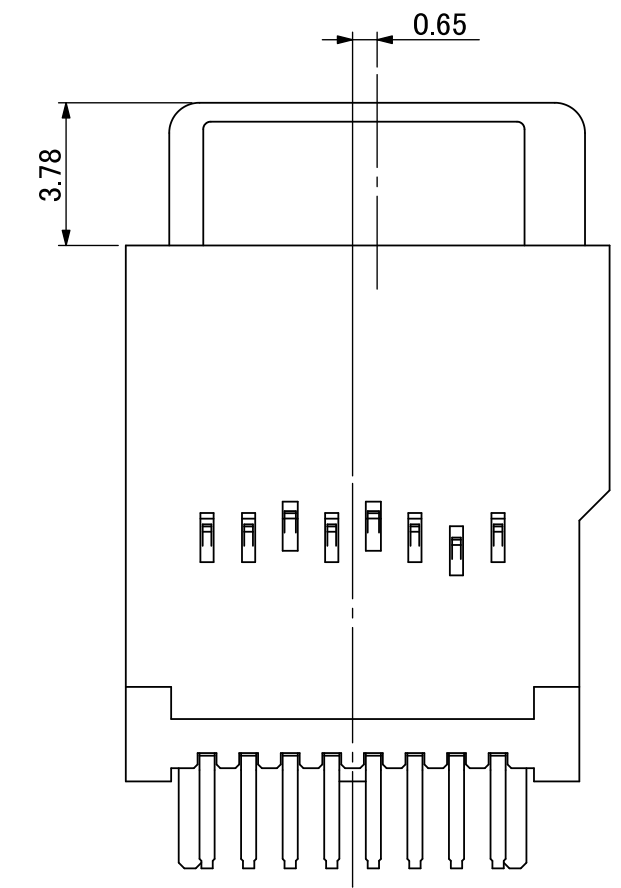
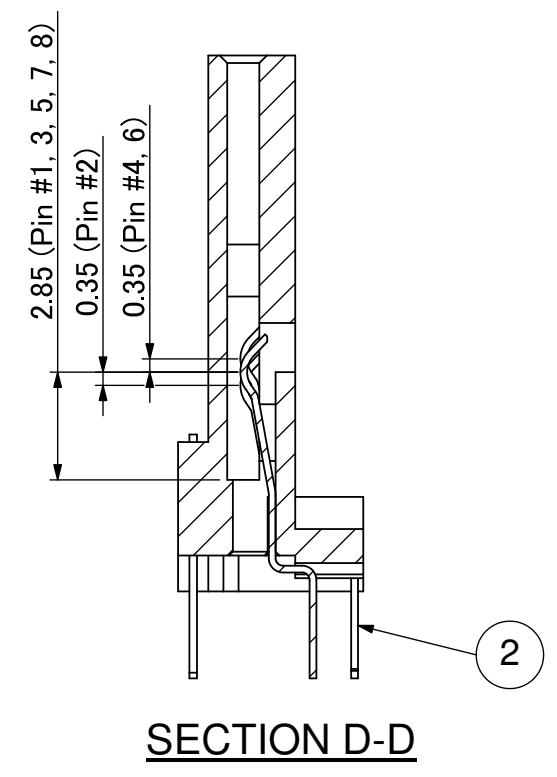
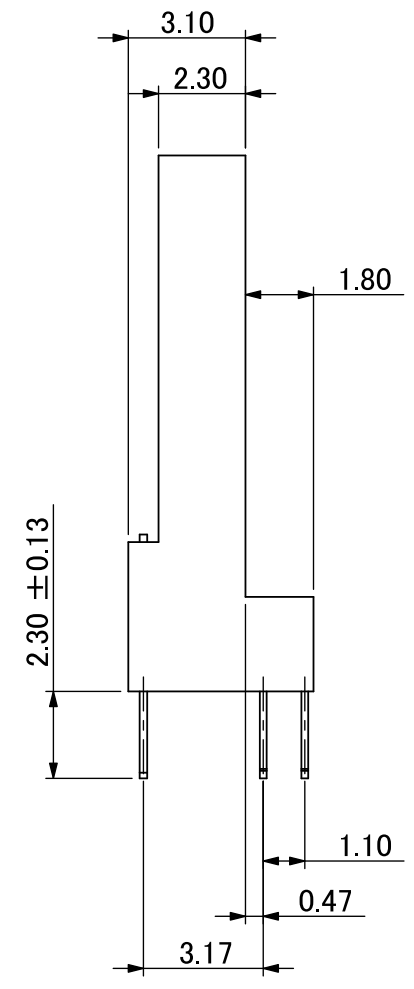
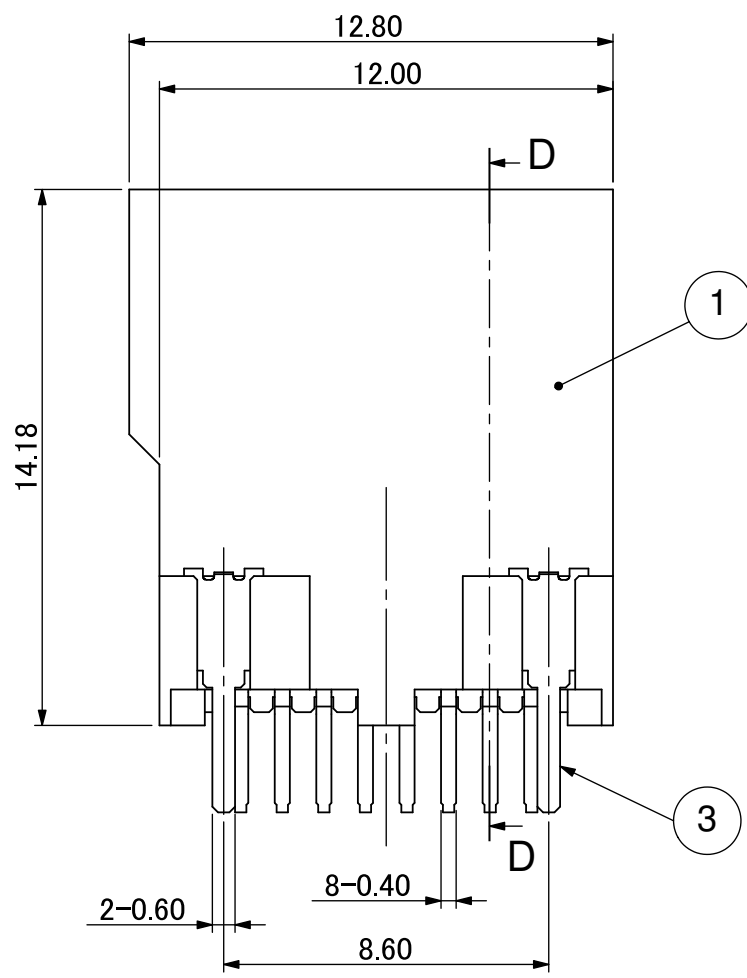
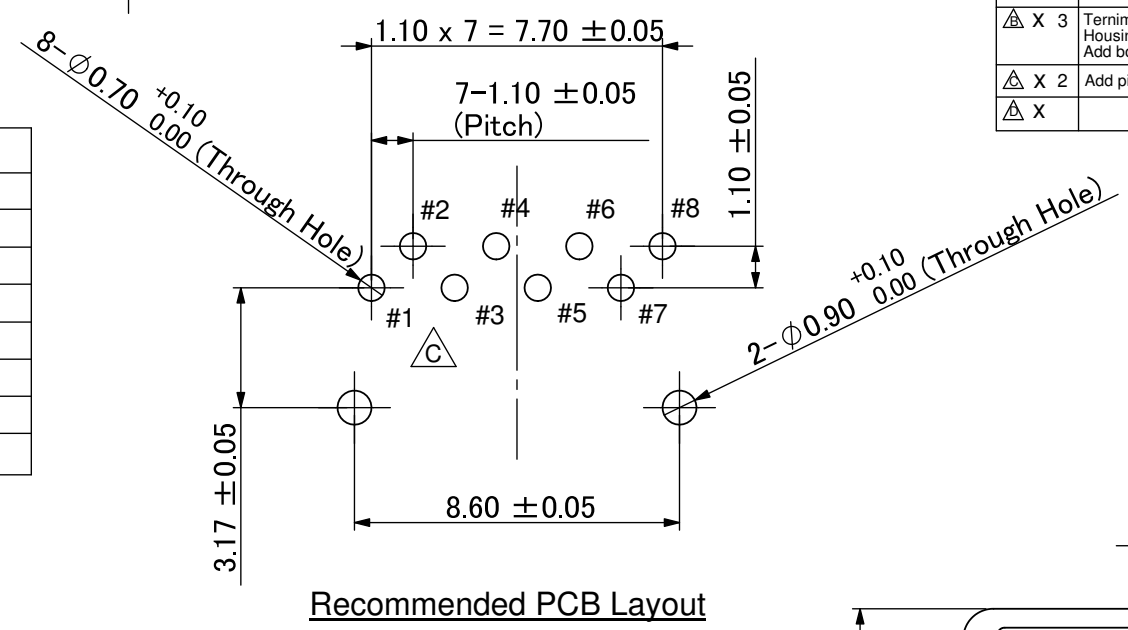
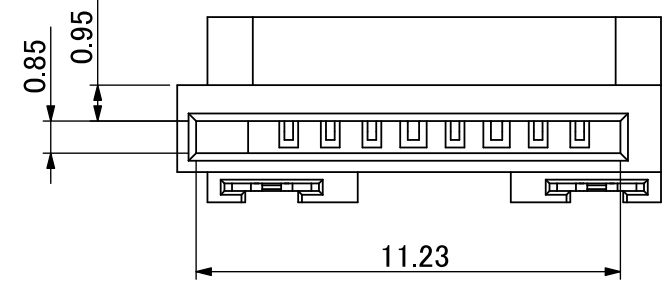

Item No.	Description	Qty.	Material	Content
3	DIP pin	2	Brass, t=0.20	Ni-Tin
2	Contact	8	PB, t=0.18	Ni-Au/Tin
1	Housing	1	LCP	Black

Tolerances ±0.3 unless otherwise specified. () Reference value									
CLASS microSD manual, Vertical mount						Part # PJS008U-3000-0			
SCALE 5 / 1	APP.	APP.	CHK.	DRW.	DSGN.	DRW No. YEU-A1146		Sheet No. /	REV. C
DIMENSION mm	04/01/09	04/01/09	04/01/09	04/01/09	04/01/09				
ANGLE PROJ 3rd	T. Nishimura	T. Nishimura	K. Abe	K. Abe					A3-001