

**THINKING ELECTRONIC INDUSTRIAL CO., LTD.**

HEAD OFFICE: 8F-1, No.93, Ta-Shun 1st Rd., Kaohsiung, Taiwan  
 TEL: 886-7-5577660 FAX: 886-7-5570560

## MANUFACTURING SITE

- KAOHSIUNG FACTORY: No.51, Kaifa Road, Nantze Export Processing Zone,  
 Kaohsiung City 81170, Taiwan  
 TEL: 886-7-9616668 FAX: 886-7-9616698
- CHANGZHOU FACTORY: No.82, Renmin Mid Rd., WuJin High&New-Tech Industrial  
 Development Zone, ChangZhou, JiangSu, China  
 TEL: 86-519-86578999 FAX: 86-519-86558643
- DONG GUAN FACTORY: Chiao-Tou Tsun, Sha-Tao Hsiang, Chang-An Town,  
 Dong-Guan City 523863, Guangdong, China  
 TEL: 86-769-85542016 FAX: 86-769-85546890
- YICHANG FACTORY: No. 283 Xiaoting Avenue, Xiaoting Dist., Yichang  
 City 443007, Hubei, China  
 TEL: 86-717-6510010 FAX: 86-717-6511430

**SPECIFICATION FOR APPROVAL**

CUSTOMER	CODICO
CERTIFIED MODEL/TYPE	TVR05271
PART NO.	TVR05271KSARY(RoHS)
APPLICATION	
CUSTOMER P/N	
ISSUE DATE	Mar.25.2016
REV. NO	
REV. DATE	

FOR CUSTOMER APPROVAL	CHECKED BY
	Yuan Yuan
	APPROVED BY
	Huaifang Zhang





**REVISED RECORD SHEET**

REV. NO	REV. DATE	REVISED CONTENT



<b>INDEX</b>	<b>Page</b>
■ Part Number Code	1
■ Structure and Dimensions	2
■ Electrical Characteristics	2
■ Reliability	3 ~ 4
■ Soldering Recommendation	5
■ Power Derating Curve	6
■ RoHS Compliant Declaration	6
■ Warehouse Storage Conditions of Products	6
■ Taping and Dimensions	7
■ Packaging	8
■ Certificates	9
■ Max. Surge Current Derating Curves	10
■ Max. Leakage Current and Max. Clamping Voltage Curve	11

Part Number Code

Example :

<b><u>TVR</u></b>	<b><u>05</u></b>	<b><u>271</u></b>	<b><u>K</u></b>	<b><u>S</u></b>	<b><u>AR</u></b>	<b><u>Y</u></b>
(1)	(2)	(3)	(4)	(5)	(6)	(7)

No.	Item	Digit	Specification
(1)	Product Type	TVR	Thinking varistor TVR type
(2)	Body Size	05	φ 05 mm
(3)	Varistor Voltage	271	$27 \times 10^1 V = 270V (V1mA)$
(4)	Tolerance of $V_{1mA}$	K	±10%
(5)	Appearance	S	Straight Lead , Epoxy Coating
(6)	Packaging	A	Repositioning tapping( hole pitch: 12.7mm)
		R	reel
(7)	Optional Suffix	Y	RoHS compliance

### Structure and Dimensions

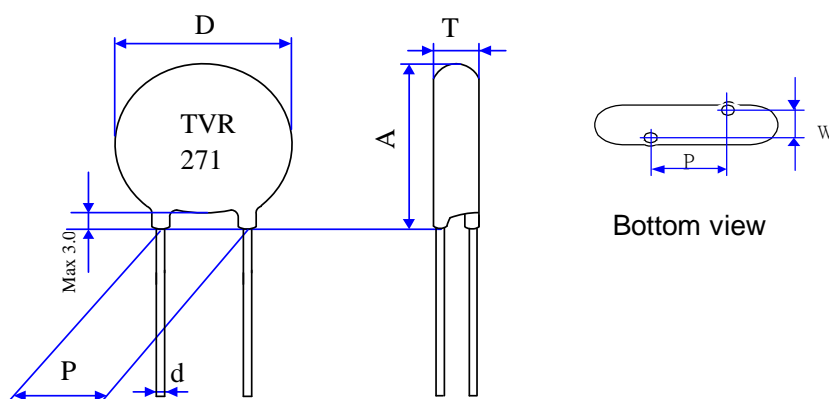

( unit : mm )

Body Size	D	P	d	A max.	T	W
$\phi 05$	5.0~7.0	5.0 $\pm$ 0.5	0.60 $\pm$ 0.02	9.0	2.4~4.4	1.7 $\pm$ 1.0

**\*Coating material rating:UL 94 V-0**

### Electrical Characteristics ( Ambient $T_a=25^\circ\text{C}$ )

Part No.	Varistor Voltage (@ 1mA DC)	Max. Continuous Voltage		Max. Clamping Voltage (8/20 $\mu$ S)		Max. Surge Current (8/20 $\mu$ S)	Max. Energy (10/1000 $\mu$ S)
	$V_{1mA}$ (V)	$V_{AC}(rms)$ (V)	$V_{DC}$ (V)	$V_p$ (V)	$I_p$ (A)	I (A)	W (J)
TVR05271KSARY	270 $\pm$ 10 %	175	225	475	5	400	8.5

Part No.	Rated Power	Impulse Response Time	Max. Leakage Current at 75% $V_{1mA}$	Operating Temperature Range	Storage temperature Range
	P (W)	nSec	$I_L(\mu A)$	( $^\circ\text{C}$ )	( $^\circ\text{C}$ )
TVR05271KSARY	0.1	<25	20	-40 ~ +85	-40 ~ +125



Reliability

Item	Standard	Test conditions / Methods	Specifications															
Tensile Strength of Terminals	IEC60068-2-21	<p>Gradually applying the force specified and keeping the unit fixed for 10±1 sec.</p> <table border="1"> <thead> <tr> <th>Terminal diameter (mm)</th> <th>Force (Kg)</th> </tr> </thead> <tbody> <tr> <td>0.5&lt;d≤0.8</td> <td>1.0</td> </tr> <tr> <td>0.8&lt;d≤1.25</td> <td>2.0</td> </tr> <tr> <td>1.25&lt;d</td> <td>4.0</td> </tr> </tbody> </table>	Terminal diameter (mm)	Force (Kg)	0.5<d≤0.8	1.0	0.8<d≤1.25	2.0	1.25<d	4.0	No visible damage   ΔV/V <sub>1mA</sub>   ≤5%							
Terminal diameter (mm)	Force (Kg)																	
0.5<d≤0.8	1.0																	
0.8<d≤1.25	2.0																	
1.25<d	4.0																	
Bending Strength of Terminals	IEC60068-2-21	<p>Hold specimen and apply the force specified below to each lead. Bend the specimen to 90°, then return to the original position. Repeat the procedure in the opposite direction.</p> <table border="1"> <thead> <tr> <th>Terminal diameter (mm)</th> <th>Force (Kg)</th> </tr> </thead> <tbody> <tr> <td>0.5&lt;d≤0.8</td> <td>0.5</td> </tr> <tr> <td>0.8&lt;d≤1.25</td> <td>1.0</td> </tr> <tr> <td>1.25&lt;d</td> <td>2.0</td> </tr> </tbody> </table>	Terminal diameter (mm)	Force (Kg)	0.5<d≤0.8	0.5	0.8<d≤1.25	1.0	1.25<d	2.0	No visible damage   ΔV/V <sub>1mA</sub>   ≤5%							
Terminal diameter (mm)	Force (Kg)																	
0.5<d≤0.8	0.5																	
0.8<d≤1.25	1.0																	
1.25<d	2.0																	
Vibration	IEC 60068-2-6	<p>Frequency range:10~55Hz Amplitude:0.75mm or 98m/S<sup>2</sup> Direction:3 mutually perpendicular directions,2hrs each.</p>	ΔV/V <sub>1mA</sub>   ≤5% No visible damage															
Solderability	IEC60068-2-20	245 ± 3 °C , 3 ± 0.3 sec	At least 95% of terminal electrode is covered by new solder															
Resistance to Soldering Heat	IEC60068-2-20	260 ± 3 °C , 5 ± 1 sec	No visible damage   ΔV/V <sub>1mA</sub>   ≤5%															
High Temperature Storage	IEC60068-2-2	125 ± 5 °C , 1000 ± 24 hrs	No visible damage   ΔV/V <sub>1mA</sub>   ≤5%															
Damp Heat, Steady State	IEC 60068-2-78	<p>The test is divided into two groups . a.40 ± 2°C , 90 ~ 95 % RH , 1344 hrs b.40 ± 2°C , 90 ~ 95 % RH , at 10%V<sub>DC</sub>, 1344 hrs</p>	No visible damage   ΔV/V <sub>1mA</sub>   ≤10% Insulation Resistance ≥ 100MΩ															
Rapid Change of Temperature	IEC60068-2-14	<p>The conditions shown below shall be repeated 5 cycles</p> <table border="1"> <thead> <tr> <th>Step</th> <th>Temperature (°C)</th> <th>Period (minutes)</th> </tr> </thead> <tbody> <tr> <td>1</td> <td>-40 ± 3</td> <td>30 ± 3</td> </tr> <tr> <td>2</td> <td>Room temperature</td> <td>5 ± 3</td> </tr> <tr> <td>3</td> <td>85 ± 2</td> <td>30 ± 3</td> </tr> <tr> <td>4</td> <td>Room temperature</td> <td>5 ± 3</td> </tr> </tbody> </table>	Step	Temperature (°C)	Period (minutes)	1	-40 ± 3	30 ± 3	2	Room temperature	5 ± 3	3	85 ± 2	30 ± 3	4	Room temperature	5 ± 3	No visible damage   ΔV/V <sub>1mA</sub>   ≤5%
Step	Temperature (°C)	Period (minutes)																
1	-40 ± 3	30 ± 3																
2	Room temperature	5 ± 3																
3	85 ± 2	30 ± 3																
4	Room temperature	5 ± 3																
High Temp. Load	MIL-STD-202 Method 108	85 ± 2 °C , 1000 ± 24 hrs, at V <sub>DC</sub> or V <sub>rms</sub> (Max. Operating Voltage)	ΔV/V <sub>1mA</sub>   ≤10% No visible damage															



Item	Standard	Test conditions / Methods	Specifications
8/20 $\mu$ S Surge Life	IEC 61051-1 4.6	10,000 pulses( 8/20 $\mu$ S ) , unipolar, interval 10 secs, amplitude corr. to max. Surge current derating curves for 20 $\mu$ S	$ \Delta V/V_{1mA}  \leq 10\%$ No visible damage
10/1000 $\mu$ S Surge Life	IEC 61051-1 4.6	10/1000 $\mu$ S waveform, 10 surge currents,unipolar,interval 2mins, amplitude corr. to max. surge current derating curves for 1000 $\mu$ S	$ \Delta V/V_{1mA}  \leq 10\%$ No visible damage
Varistor Voltage Temp. Coeffient	Specification Standard	$\frac{V_{1mA} \text{ at } 85^{\circ}\text{C} - V_{1mA} \text{ at } 25^{\circ}\text{C}}{V_{1mA} \text{ at } 25^{\circ}\text{C}} \times \frac{1}{60} \times 100 (\% / ^{\circ}\text{C} )$ $\frac{V_{1mA} \text{ at } -40^{\circ}\text{C} - V_{1mA} \text{ at } 25^{\circ}\text{C}}{V_{1mA} \text{ at } 25^{\circ}\text{C}} \times \frac{1}{65} \times 100 (\% / ^{\circ}\text{C} )$	$-0.05 \leq TC \leq 0.05 (\% / ^{\circ}\text{C} )$
Voltage Proof	IEC 61051-1 4.9	Metal balls method, 2500 Vac 1 min	No visible damage

## Soldering Recommendation

### ■ Wave Soldering Profile

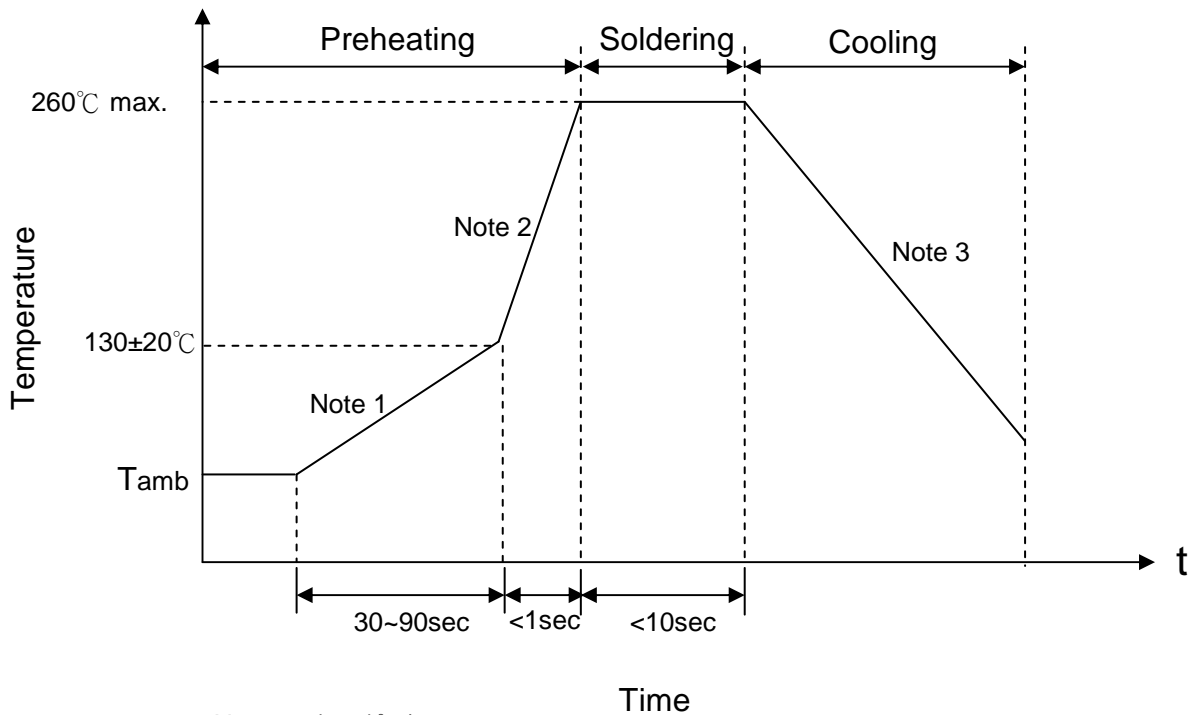

- Note 1 :  $(1\sim3)^\circ\text{C}/\text{sec}$   
 Note 2 : Approx.  $200^\circ\text{C}/\text{sec}$   
 Note 3 :  $5^\circ\text{C}/\text{sec Max}$

### ■ Recommended Reworking Conditions with Soldering Iron

Item	Conditions
Temperature of Soldering Iron-tip	$360^\circ\text{C}$ (max.)
Soldering Time	3 sec (max.)
Distance from Varistor	2 mm (min.)



### Power Derating Curve

When operating temperature exceeds 85°C, the power, the Max.continuous operation Voltage,the Max.Surge Current and the Max.Energy should be derated as below figure, the derated coefficient is -2.5%.

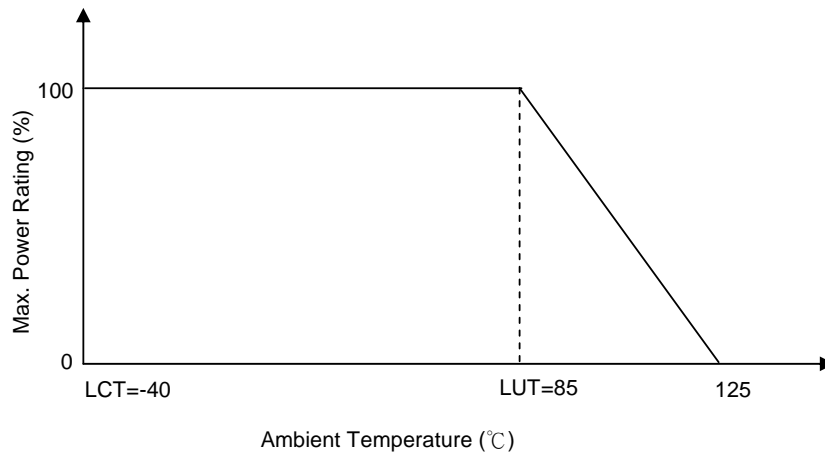

### RoHS Compliant Declaration

We hereby declare that the components delivered to your company are compliant with RoHS directive 2011/65/EU.

### Warehouse Storage Conditions of Products

(I) Storage Conditions :

- 1.Storage Temperature : -10°C ~+40°C
- 2.Relative Humidity :  $\leq 75\%RH$
- 3.Keep away from corrosive atmosphere and sunlight.

(II) Period of Storage : 1 year

Taping and Dimensions

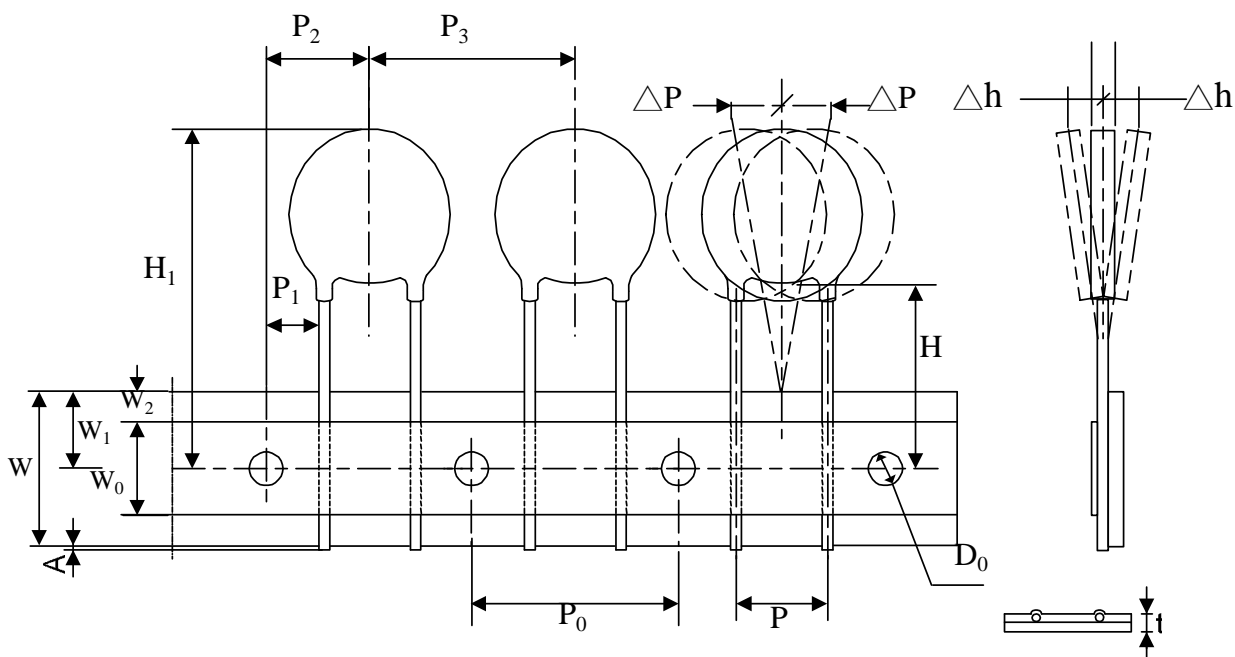

ITEM.	P <sub>0</sub>	P	P <sub>1</sub>	P <sub>2</sub>	P <sub>3</sub>	H	H <sub>1</sub> Max	W <sub>0</sub>	W <sub>1</sub>	W <sub>2</sub> Max	W	ΔP Max	Δh Max	A Max	D <sub>0</sub>	t
Nor.	12.7	5.0	3.55	6.35	12.7	18	28	12	9	3	18	1.0	2.0	0.5	4	0.6
ToL.	±0.3	±0.5	±1	±1.3	±1	+2/-0	---	±1	+0.75/ -0.5	---	±1	---	---	---	±0.2	±0.2

(Unit:mm)

Packaging

(1) SPQ: 1500 Pcs/ Reel

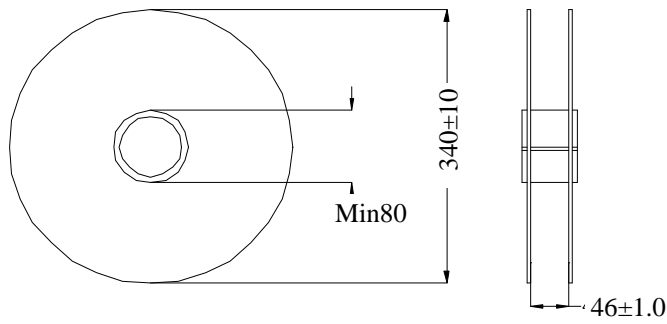

(2) Inner Box: 1 Reel/ Box

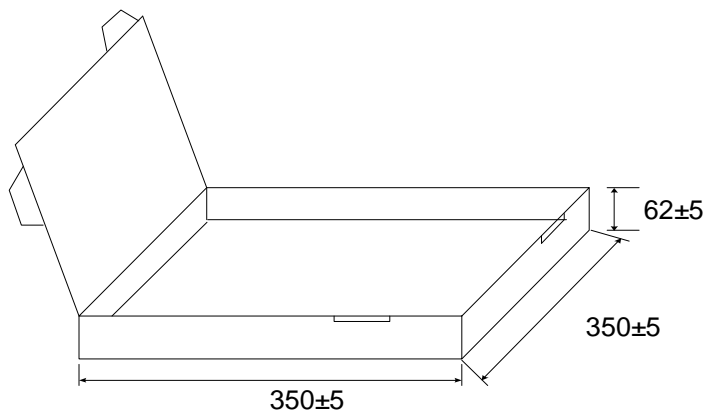

(3) Outer Box: 4Boxes/ Carton

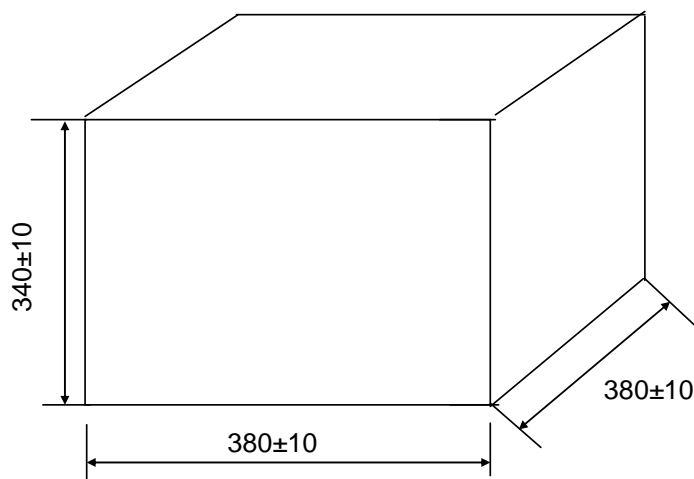

(Unit:mm)

Safety Approvals (Certified Model/Type :TVR05271)

\* UL 1449 4th / cUL recognized (File # E314979)



\*CSA 22.2 recognized (File # 97495)



\* VDE IEC 61051-1:2007-04 / IEC 61051-2:1991  
IEC 61051-2-2:1991 recognized (File # 5944)



\* CQC GB/T10193-1997 \ GB/T10194-1997 recognized  
(File # CQC03001005165/CQC03001007654)

Certificates

- (1) TS 16949 certificate
- (2) ISO 9001 certificate

Test Report

- (1) RoHS test report



Max. Surge Current Derating Curves

TVR05271KSARY

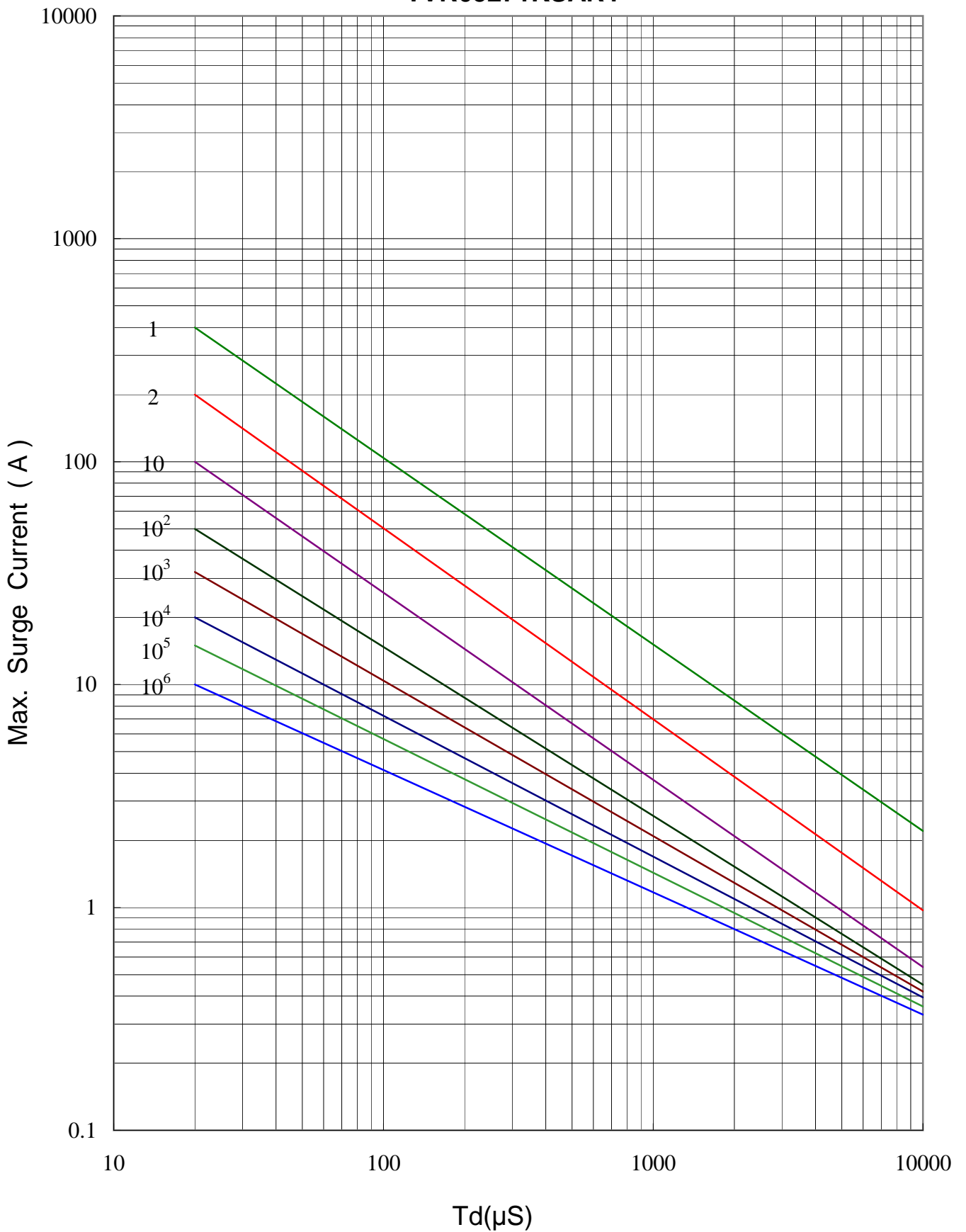



Max. Leakage Current and Max. Clamping Voltage Curve

**TVR05271KSARY**

