



Ag5400

High Efficiency 30W Power-over-Ethernet Module

Features

- 30W (IEEE802.3at) output power
- >93% efficient DC/DC converter
- 5V, 12V and 24V variants available
- Very low heat output
- Low output ripple & noise
- Overload, short-circuit and thermal protection
- Adjustable output voltage
- Industrial temperature range
- Minimal external components required
- Class 4 IEEE802.3 PD
- IEEE802.3bt, IEEE802.3at, IEEE802.3af compliant
- Small Single In-Line (SIL) package size – 57.3mm (L) x 14mm (H)
- 1500Vdc isolation (input to output)
- Silvertel “design-in” assistance

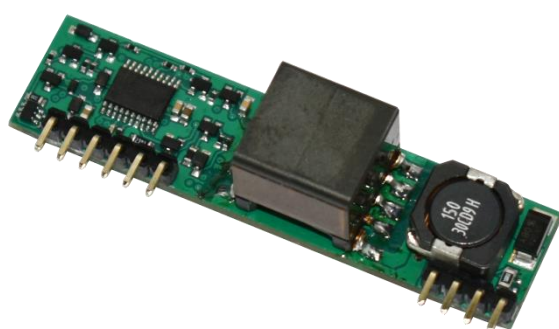

Description

The Ag5400 series Power-over-Ethernet (PoE+) modules are designed to extract power from a conventional twisted pair Category 5 Ethernet cable, conforming to the IEEE802.3 PoE standard, with full backwards compatibility with the IEEE802.3bt, IEEE802.3at and IEEE802.3af amendments.

The Ag5400 is pre-configured as a Type 2 Class 4 device, allowing the module to draw up to 30W of power from the PSE, with nominal output voltages of 5V, 12V or 24V.

The high efficiency DC/DC converter can achieve in excess of 93% efficiency and operates over a wide input voltage range with a low ripple and low noise output. The DC/DC converter also has built-in output overload, output short-circuit and over-temperature protection and provides a 1500Vdc (input to output) isolation barrier.

Table of Contents

| | | |
|----------|------------------------------------|-----------|
| 1 | Product Overview | 3 |
| 1.1 | Ag5400 Product Selector | 3 |
| 1.2 | Package Format | 3 |
| 1.3 | Pin Description | 4 |
| 2 | Functional Description | 5 |
| 2.1 | Typical Connections | 5 |
| 2.2 | Input | 6 |
| 2.2.1 | PD Signature | 6 |
| 2.2.2 | Power Classification | 6 |
| 2.2.3 | PSE Type Detection | 7 |
| 2.3 | Output | 8 |
| 2.3.1 | Maximum output power | 8 |
| 2.3.2 | Output Voltage Adjust Setting | 8 |
| 3 | Efficiency | 9 |
| 4 | Operating Temperature Range | 11 |
| 4.1 | Thermal Considerations | 12 |
| 5 | Protection | 13 |
| 5.1 | Input Protection | 13 |
| 5.2 | Output Short Circuit Protection | 13 |
| 5.3 | Thermal Protection | 13 |
| 6 | Isolation | 14 |
| 7 | EMC | 15 |
| 8 | Electrical Characteristics | 16 |
| 8.1 | Absolute Maximum Ratings | 16 |
| 8.2 | Recommended Operating Conditions | 16 |
| 8.3 | DC Electrical Characteristics | 17 |
| 9 | Package | 18 |

Table of Figures

| | | |
|------------|---|----|
| Figure 1: | Block Diagram | 3 |
| Figure 2: | Ag5400 Package Format | 3 |
| Figure 3: | Typical System Diagram | 5 |
| Figure 4: | Two Event Physical Layer Detect Configuration | 7 |
| Figure 5: | Output Voltage Adjustment | 8 |
| Figure 6: | Ag5405 Efficiency | 9 |
| Figure 7: | Ag5412 Efficiency | 10 |
| Figure 8: | Ag5424 Efficiency | 10 |
| Figure 9: | Ag5400 operating temperature profile | 11 |
| Figure 10: | Thermal Relief | 12 |
| Figure 11: | Input Protection | 13 |
| Figure 12: | Isolation Barrier | 14 |
| Figure 13: | Typical Connection Diagram | 15 |
| Figure 14: | Package Dimensions | 18 |

1 Product Overview

1.1 Ag5400 Product Selector

| Part Number ¹ | Nominal Output Voltage | Output Power | Marking ² | Package |
|--------------------------|------------------------|----------------------------|----------------------|---------|
| Ag5405 | 5V | 25.5W Continuous, 30W Peak | ab05c | SIL |
| Ag5412 | 12V | 30W Continuous | ab12c | |
| Ag5424 | 24V | 30W Continuous | ab24c | |

Note 1: Complies with the European Directive 2011/65/EU for the Restriction of use of certain Hazardous Substances (RoHS) including Directive 2015/863 published in 2015, amending Annex II of Directive 2011/65/EU. Moisture Sensitive Level 1 and HBM 1.

Note 2: The first letter, a, indicates the week as A-Z with uppercase being weeks 1-26, lower case weeks 27-52.
 The second letter, b, indicates the year in uppercase A-Z starting from 2020.
 The two digits are the nominal output voltage,
 The final letter, c, is a Silvertel reference.

Table 1: Ordering Information

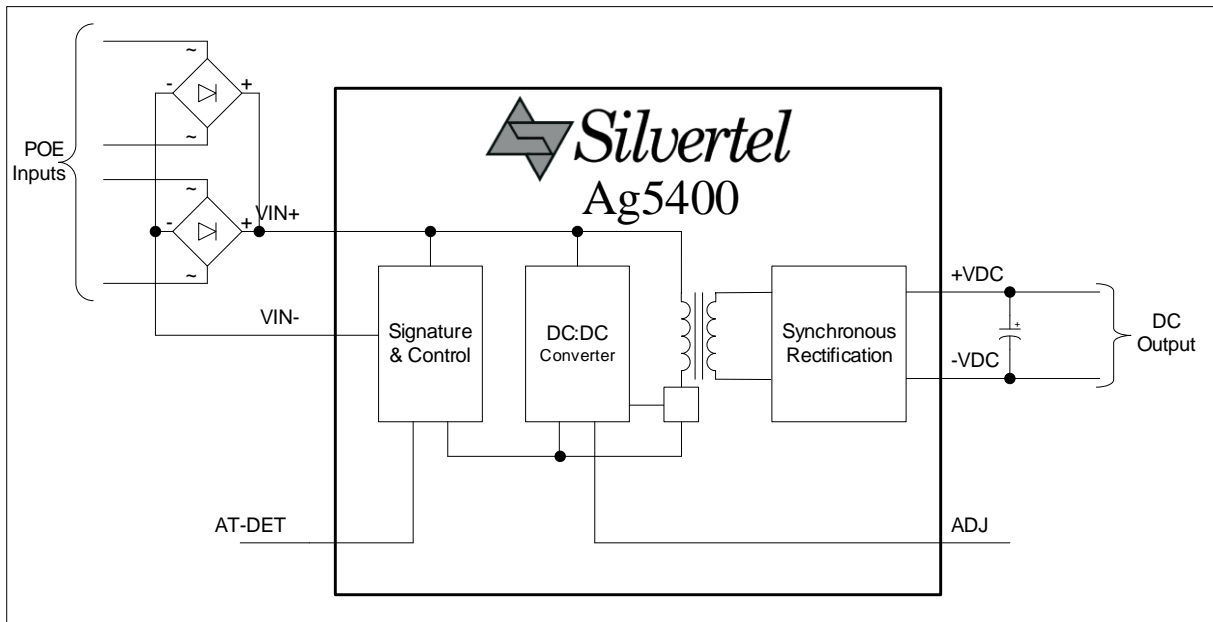

Figure 1: Block Diagram

1.2 Package Format

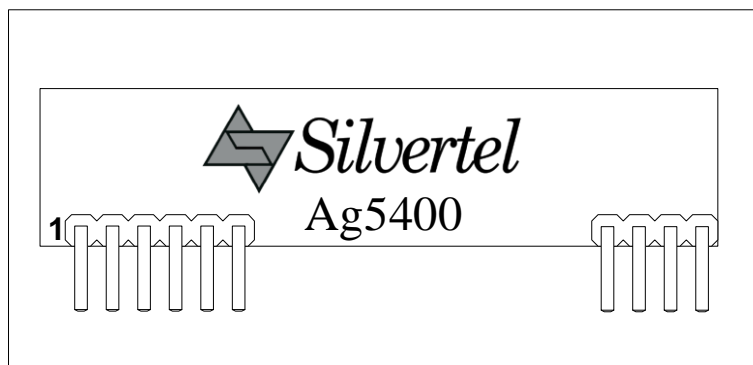

Figure 2: Ag5400 Package Format

1.3 Pin Description

| Pin # | Name | Description |
|-------|--------|---|
| 1 | VIN+ | POE Direct Input +. This pin connects to the positive (+) output of the POE input bridge rectifiers. |
| 2 | VIN- | POE Direct Input -. This pin connects to the negative (-) output of the POE input bridge rectifiers. |
| 3 | AT-DET | AT Detect Output. This pin indicates if an IEEE802.3at PSE is supplying power to the Ag5400; see Section 2.2.3 for more details. |
| 4 | IC | Internal Connection. Do not connect to this pin. |
| 5 | IC | Internal Connection. Do not connect to this pin. |
| 6 | IC | Internal Connection. Do not connect to this pin. |
| | | |
| 7 | -VDC | Negative DC Output. This pin provides the negative regulated output from the Ag5400 and is internally connected to pin 10. |
| 8 | +VDC | Positive DC Output. This pin provides the positive regulated output from the Ag5400. |
| 9 | ADJ | Output Adjust. The output voltage can be adjusted from its nominal value, by connecting an external resistor from this pin to either the +VDC pin or the -VDC pin. |
| 10 | -VDC | Negative DC Output. This pin provides the negative regulated output from the Ag5400 and is internally connected to pin 7. |

Table 2: Pin Description

2 Functional Description

2.1 Typical Connections

The Ag5400 only requires a few external components - the bridge rectifiers on the V_{IN} input are to conform to the input polarity protection requirement. The $470\mu\text{F}$ capacitor (C1) connected across the output is required for correct operation of the DC/DC converter. This capacitor must be positioned as close to the output pins as possible for optimal stability. It can be a low cost electrolytic capacitor (a minimum of $470\mu\text{F}$ 16V is recommended for 12V) as shown in Figure 3; it does not need to be a low ESR type for operation in temperatures down to 0°C . But if ambient temperatures below 0°C are expected, a capacitor that retains a moderately low ESR and the minimum capacitance is essential for operation. Polymer Aluminium Solid Electrolytic Capacitors are ideal for this application.

The output voltage can be adjusted by simply connecting a resistor between the ADJ pin and either the +VDC Pin or the -VDC pin, see section 2.3.2 Output Voltage Adjust Setting.

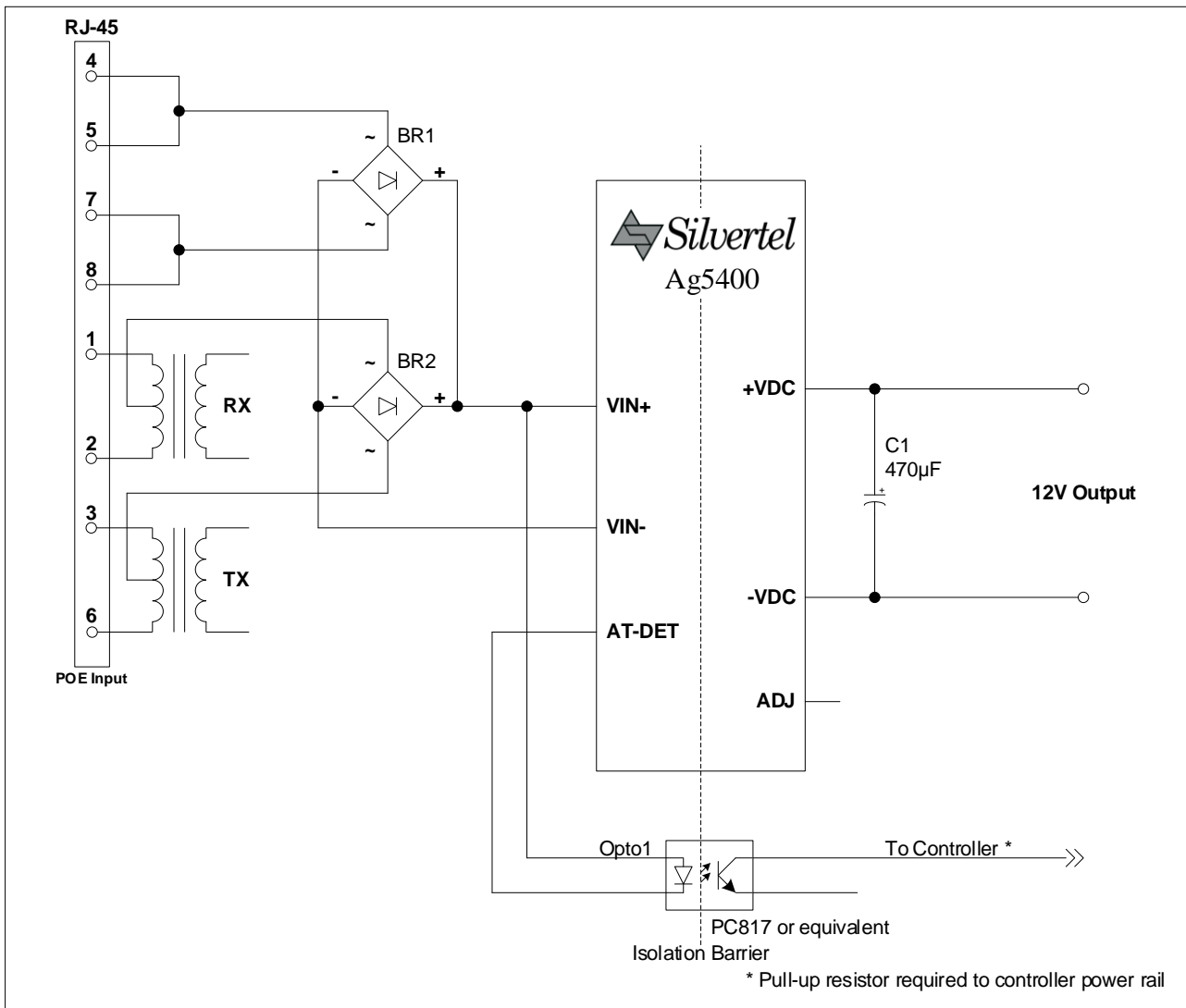

Figure 3: Typical System Diagram

2.2 Input

The Ag5400 has two input pins VIN+ and VIN-, these pins should be connected to the outputs of two external bridge rectifiers (see Figure 3: Typical System Diagram). This allows the Ag5400 to be compatible with Power Sourcing Equipment (PSE) that uses the different power options (power on the Data Pair or power on the Spare Pair).

The Ag5400 is designed to be powered by any compliant IEEE802.3 PSE such as SilverTel's Ag6120.

2.2.1 PD Signature

The Ag5400 complies with the IEEE802.3 specifications and provides signature and control circuitry specified within. When the inputs are connected to a PSE, they will automatically present a Powered Device (PD) signature to the PSE (when requested). The equipment will then recognise that a PD is connected to that line and supply power.

2.2.2 Power Classification

The Ag5400 is a fixed Type 2 - Class 4 PD requesting 30W of power from a compliant IEEE802.3 Type 2 or greater PSE by displaying the correct class pulses shown in Table 3 below. If the Ag5400 is connected to a Type 1 PSE, the PSE will not recognise the Class 4 request from the Ag5400 and default to a Class 3 power level device and supply 15.4W.

| Type | Requested Class | Class Pulse A | Class Pulse B | PSE Output Power (W) | Min. Available PD Power (W) | IEEE Spec. Amendment |
|------|-----------------|---------------|---------------|----------------------|-----------------------------|----------------------|
| 1 | 1 | 1 | N/A | 4 | 3.84 | 802.3af |
| | 2 | 2 | N/A | 7 | 6.49 | |
| | 3 | 3 | N/A | 15.4 | 13 | |
| 2 | 4 | 4 | 4 | 30 | 25.5 | 802.3at |
| 3 | 5 | 4 | 0 | 45 | 40 | 802.3bt |
| | 6 | 4 | 1 | 60 | 51 | |
| 4 | 7 | 4 | 2 | 75 | 62 | |
| | 8 | 4 | 3 | 90 | 71.3 | |

Table 3: Classification Table

2.2.3 PSE Type Detection

The Ag5400 has an output pin, AT-DET, to indicate that it has been connected to a PSE that can supply enough power to operate at its full power output. This pin will pull low from V_{in+} once the Ag5400 has detected a two event physical layer classification, as described in the IEEE802.3at or IEEE802.3bt specification amendments, this can be used to drive an LED or Optocoupler as shown in Figure 4.

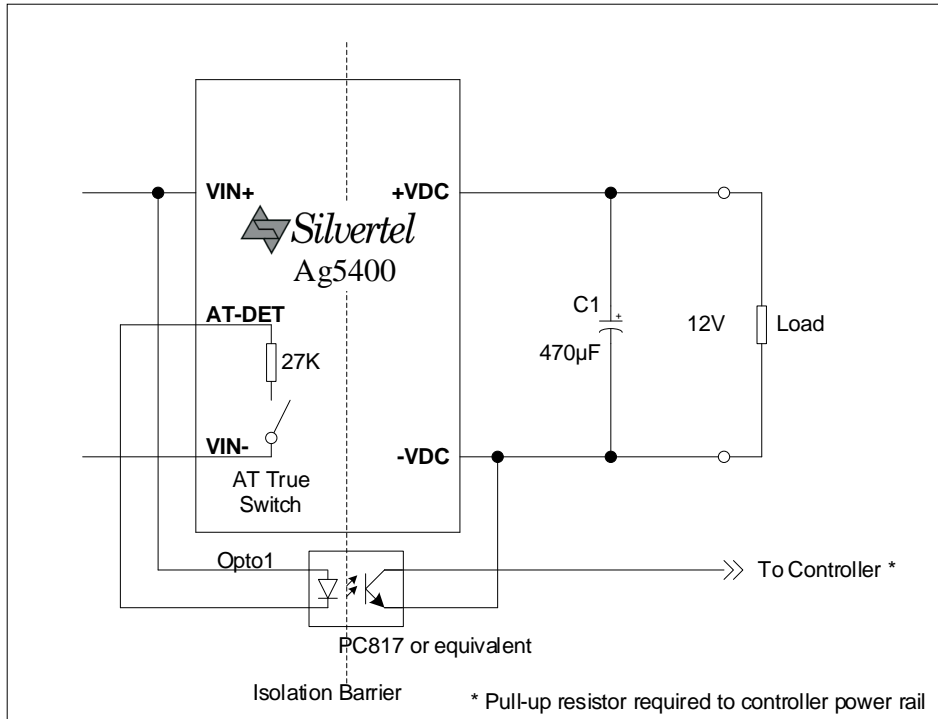

Figure 4: Two Event Physical Layer Detect Configuration.

If the Ag5400 detects a Two Event Physical Layer classification, the (AT True) switch will close and Opto1 will turn ON. Opto1 will pass this signal across the isolation barrier and the output collector can be connected to a controller (with a pull-up resistor connected to the controller's power rail). When Opto1 is ON the collector (output) will be Logic 0, the controller will then know that the PSE is capable of delivering 30W. To complete the protocol (and conform to the IEEE802.3 specification) the controller should then confirm that it is a Type 2 PD over the Data Link Layer*.

If the Ag5400 detects a Single Event Physical Layer classification, Opto1 will be OFF and the output collector will be Logic 1 (via pull-up resistor). The controller should then assume that the PSE is limited to only delivering up to 15.4W.

If the PSE does not support the Physical Layer classification, Opto1 will be OFF.

The Ag5400 may operate with non-compliant IEEE802.3 POE+ PSE's.

*There are several PSEs (including Cisco) that will only deliver $\leq 15.4W$ until they receive Type 2 PD confirmation, over the Data Link Layer.

2.3 Output

2.3.1 Maximum output power

While the Ag5400 is capable of delivering a maximum power output of 30W continuously, the maximum output power of the Ag5400 will be limited by the available power at the input pins of the module.

A Type 2 or greater (IEEE802.3at/bt) PSE supplying Class 4 power levels shall provide a minimum of 30W at its lowest voltage of 50V from its output, however with connector, cable and rectification losses, the available power and voltage at the input pins of the Ag5400 can vary considerably. In a fully compliant IEEE802.3 system, the power available, measured at the input to the bridge rectifiers, may be as low as 25.5W.

2.3.2 Output Voltage Adjust Setting

The Ag5400 has an output voltage adjustment pin, ADJ, which can be used to either increase or decrease the output voltage of the module

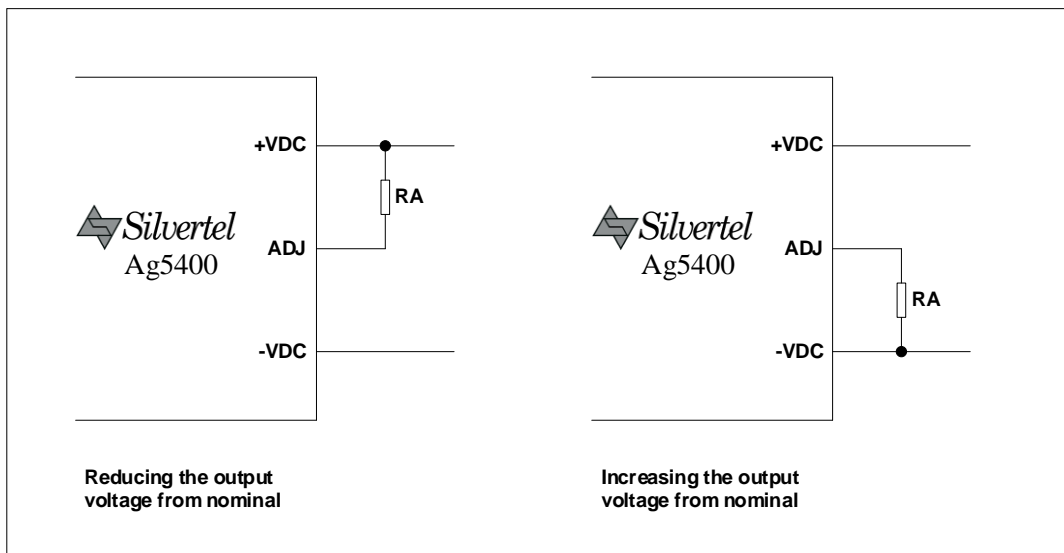

Figure 5: Output Voltage Adjustment

| Reducing the output voltage, connect RA between ADJ and +VDC | | | |
|--|---------------|--------------------|--------------------|
| Value of RA | Ag5405 output | Ag5412 output | Ag5424 output |
| Open Circuit | 5.0V | 12.0V | 24.0V |
| 68K Ohms | 4.7V | 10.8V ¹ | 21.6V ¹ |
| 0 Ohms ² | 4.4V | | |
| Increasing the output voltage, connect RA between ADJ and -VDC | | | |
| Value of RA | Ag5405 output | Ag5412 output | Ag5424 output |
| Open Circuit | 5.0V | 12.0V | 24.0V |
| 0 Ohms | 5.8V | 12.8V | 24.8V |

Table 4: Output Voltage Adjustment Resistor Values

Note 1: It is important that the minimum output adjust is not taken below this level. Setting the output voltage below this level may result in the module being permanently damaged.

Note 2: Only to be used on the Ag5405

3 Efficiency

The Ag5400 has been designed as a high efficiency PoE+ solution, In order to preserve this efficiency in the end-to-end solution; it is recommended that the Ag5400 is paired with MOSFET rectification in order to eliminate the voltage drop incurred when using diode based bridge rectification.

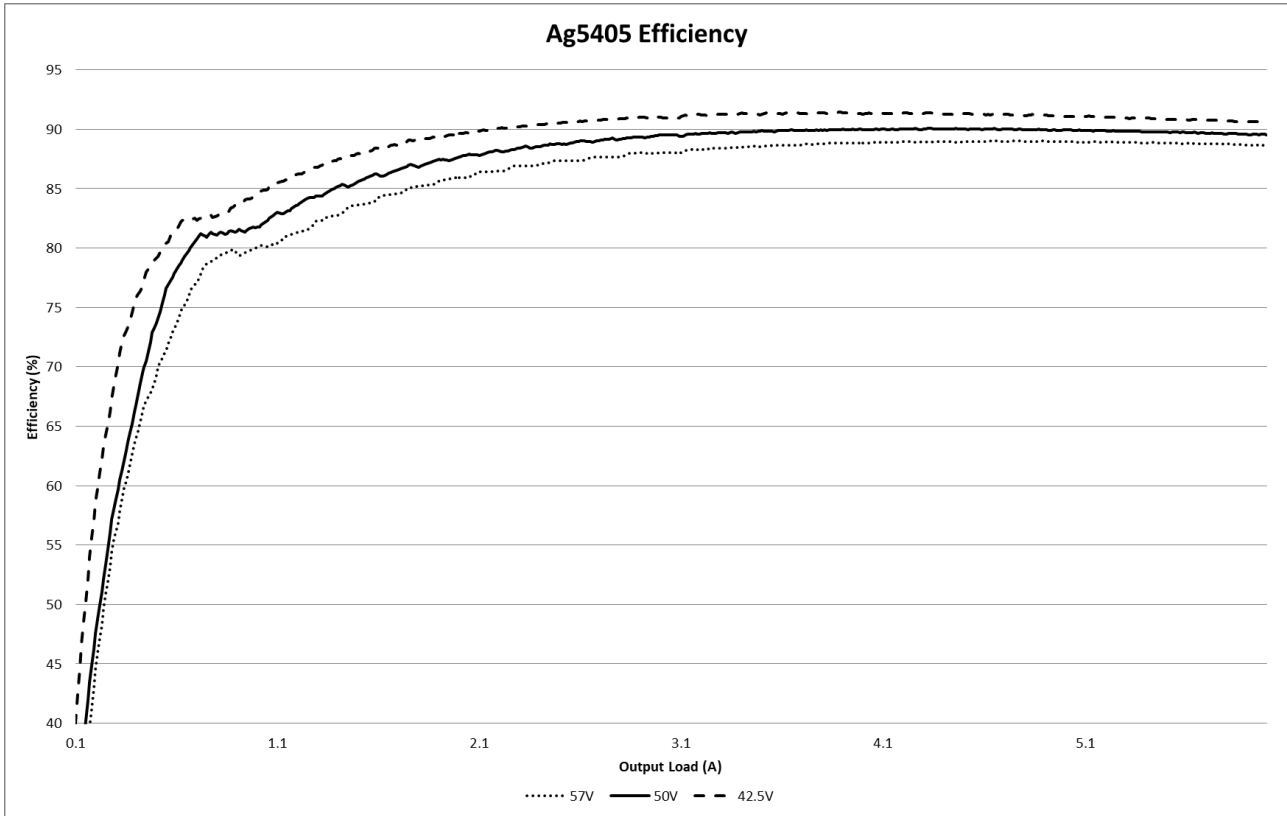

Figure 6: Ag5405 Efficiency

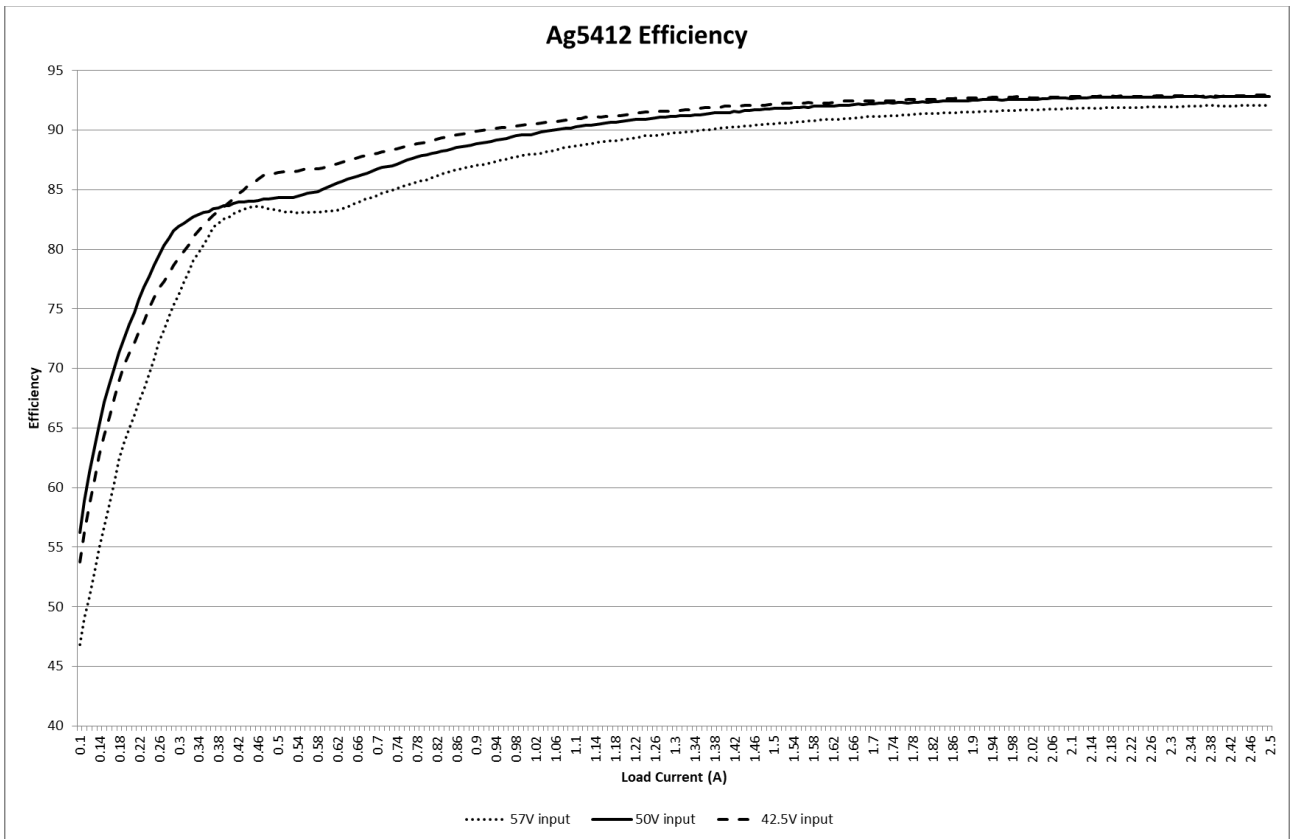

Figure 7: Ag5412 Efficiency

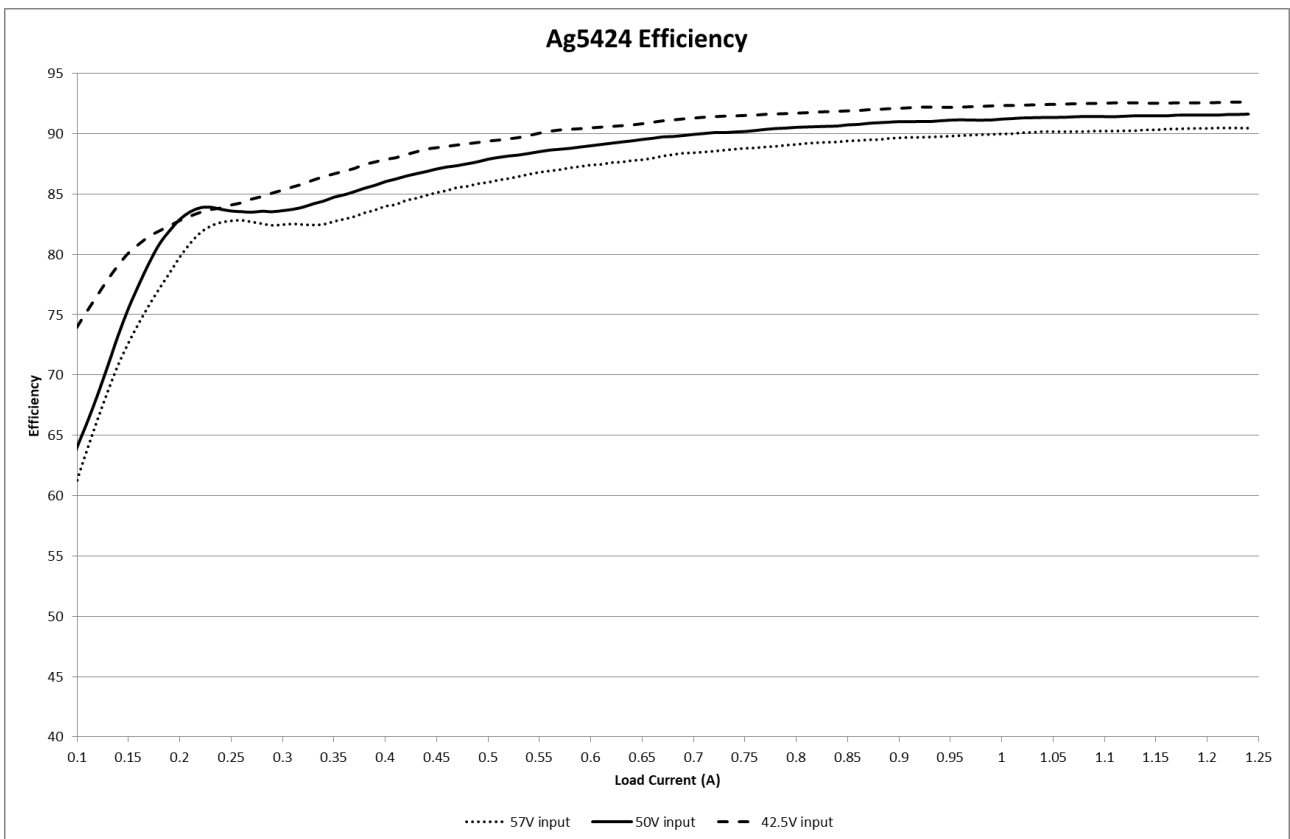

Figure 8: Ag5424 Efficiency

4 Operating Temperature Range

The core of the Ag5400 is a DC/DC converter, while this has been designed to be one of the highest efficiency modules on the market, it is still a power device and thus will generate heat, so it is important that this is taken into consideration at the design stage. The amount of heat generated by the module will depend on the load it is required to drive and the input voltage supplied by the PSE

The Ag5400 can operate up to a maximum of 85°C ambient, and a minimum of -40°C ambient. When intended for used in ambient temperatures below 0°C it is recommended that an output capacitor that will retain the minimum output capacitance and ESR ratings for the Ag5400 at the lowest temperature in the intended operating range is used. A Polymer Aluminium Electrolytic Capacitor is ideal for this application, however reputable brand rated to -55°C should suffice for most applications, please contact Silvertel if suggestions are required.

The Ag5400 is capable of utilising the full 25.5W* of guaranteed power to a class 4 device across its operating temperature range of -40°C to +85°C. The graphs shown are at the maximum ambient temperature under continuous load conditions which has been recorded in a Temperature Applied Sciences ECO MT135 Environmental chamber (with circulating air). Operation in a sealed enclosure or with limited airflow will result in de-rating of the operating temperature profile.

*due to system losses 25.5W may not be available at the output.

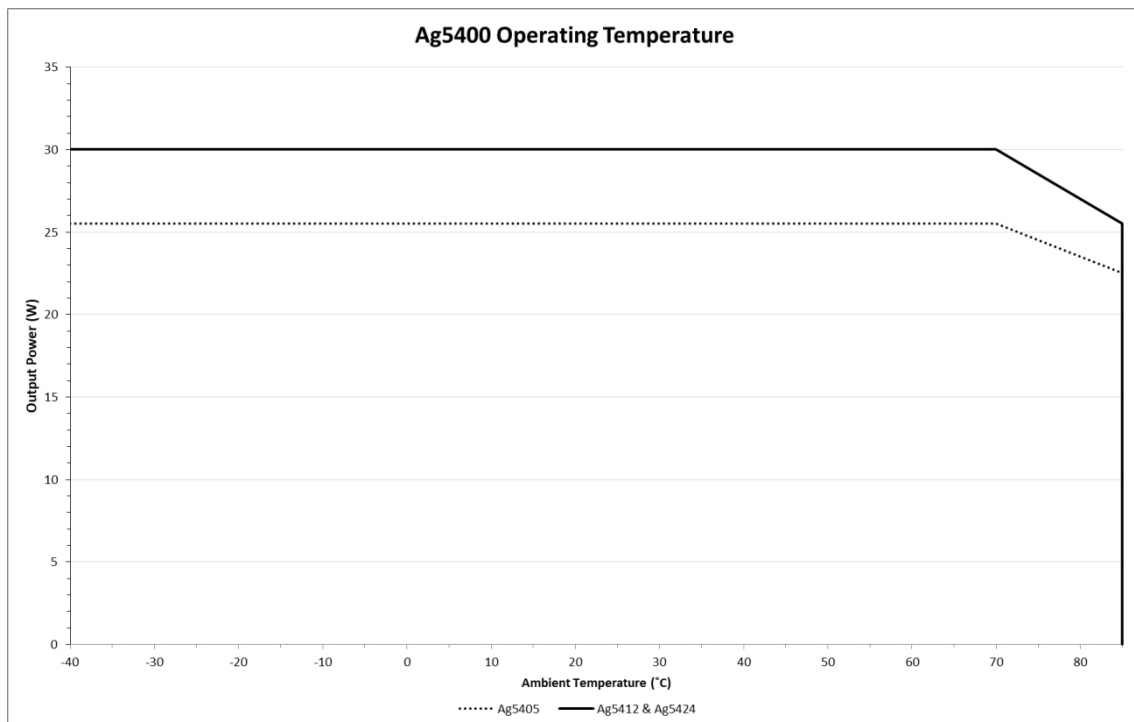

Figure 9: Ag5400 operating temperature profile

4.1 Thermal Considerations

Each application is different; therefore it is impossible to give fixed and absolute thermal recommendations. Due to the small size of this module, it is important that heat is drawn away from it. It is also important that any enclosure has sufficient ventilation for the Ag5400. For optimum effect it is recommended that the airflow be across the length of the device from pin 10 to pin 1.

One simple method for drawing some of the heat away from the Ag5400 is by means of power planes connected to the $+V_{DC}$ and $-V_{DC}$ pins of the Ag5400. This technique can be used to draw heat away from the DC/DC converter via the output pins.

These power planes must be on the outer layers of the PCB and the best results are achieved by having power planes on both sides of the main board with multiple via connections. An example of this is shown in Figure 10.

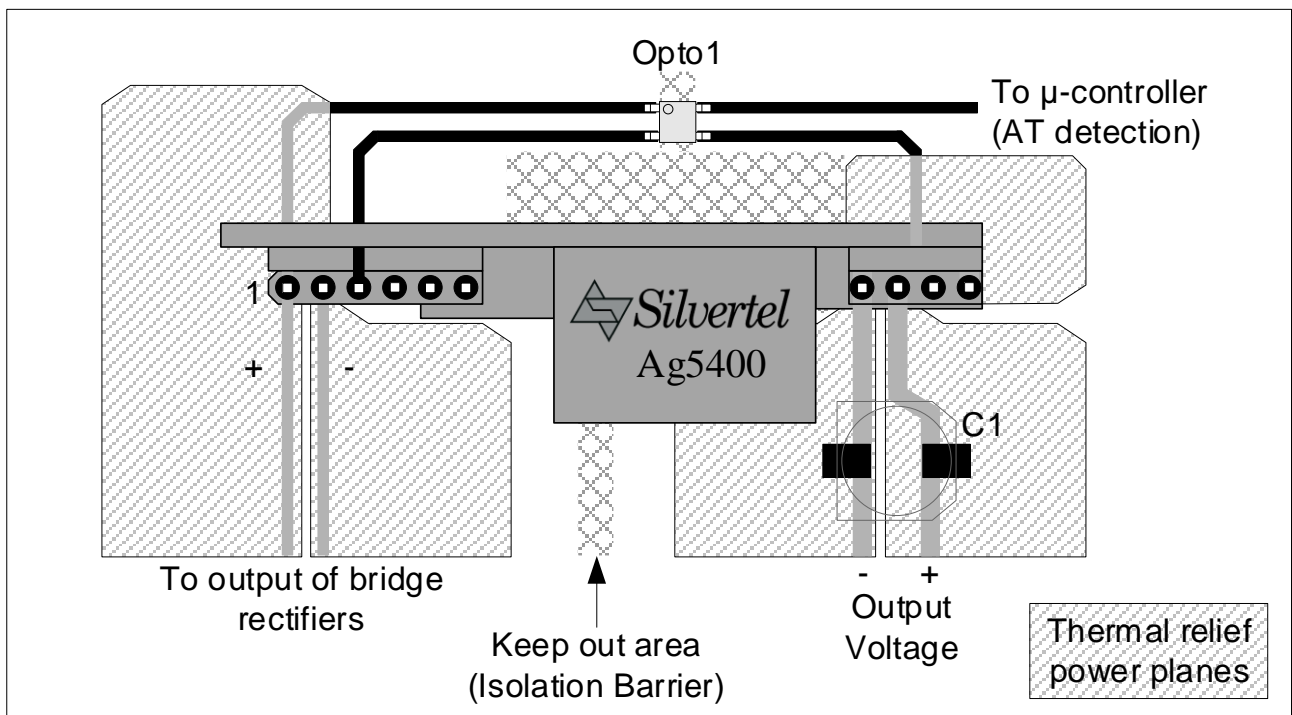

Figure 10: Thermal Relief

5 Protection

5.1 Input Protection

The Ag5400 may be damaged by input voltage transients greater than 80V. If protection from electrostatic discharge (ESD) or other high voltage transients is required, it is recommended that an over-voltage clamping device is fitted across the VIN+ and VIN- input pins. Typically an SMAJ58A will be sufficient; see Figure 11, see Apps Note “ANX-POE-Protection”.

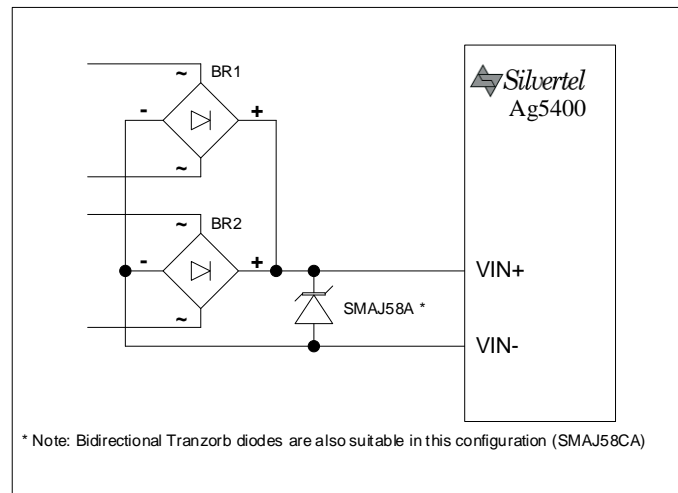

Figure 11: Input Protection

5.2 Output Short Circuit Protection

The Ag5400 has over-current protection to prevent the module from becoming damaged in the event of a short circuit event. If an over current event occurs the Ag5400 will disable the output, the Ag5400 will then test the current draw approximately every 2 seconds until the cause of the over current is removed, after which, the power will be restored to the output.

5.3 Thermal Protection

The Ag5400 contains built in thermal protection to prevent the module becoming damaged in the event that it is operated beyond its temperature specification. When the Ag5400 has detected it is over temperature, the output will be disabled until the module has cooled sufficiently.

6 Isolation

To meet the safety isolation requirements of IEEE802.3 specification, a powered device must provide electrical isolation between all its accessible external connectors, including frame ground. In order to meet this requirement the powered device should be subjected to and pass at least one of the following electrical strength tests of IEC 60950-1:2001 sub clause 6.2.1.

- a) $1500V_{rms}$ at 50-60Hz for 60 seconds
- b) $2250V_{dc}$ for 60 seconds or
- c) $1500V_{dc}$ impulse test 10 times in either polarity.

To assist in this the Ag5400 has been designed to meet and pass the $1500V_{dc}$ impulse test with no breakdown of insulation.

In order to maintain this isolation requirement, it is essential that that the isolation barrier is not breached, see ANX-POE-Isolation-Barrier for more details.

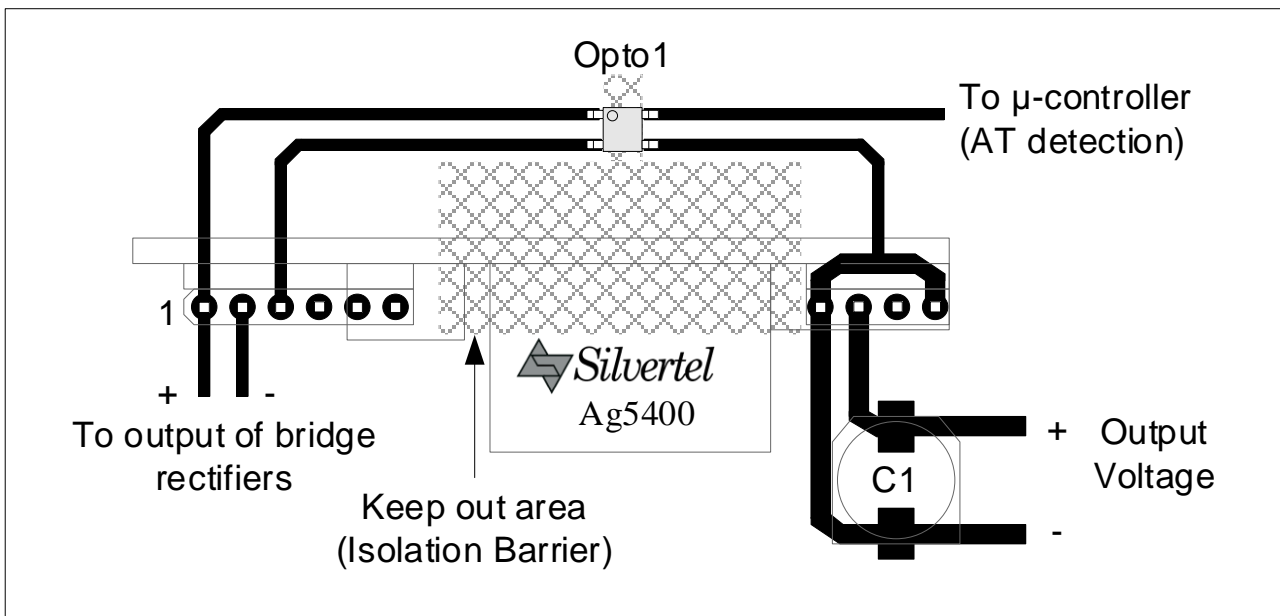
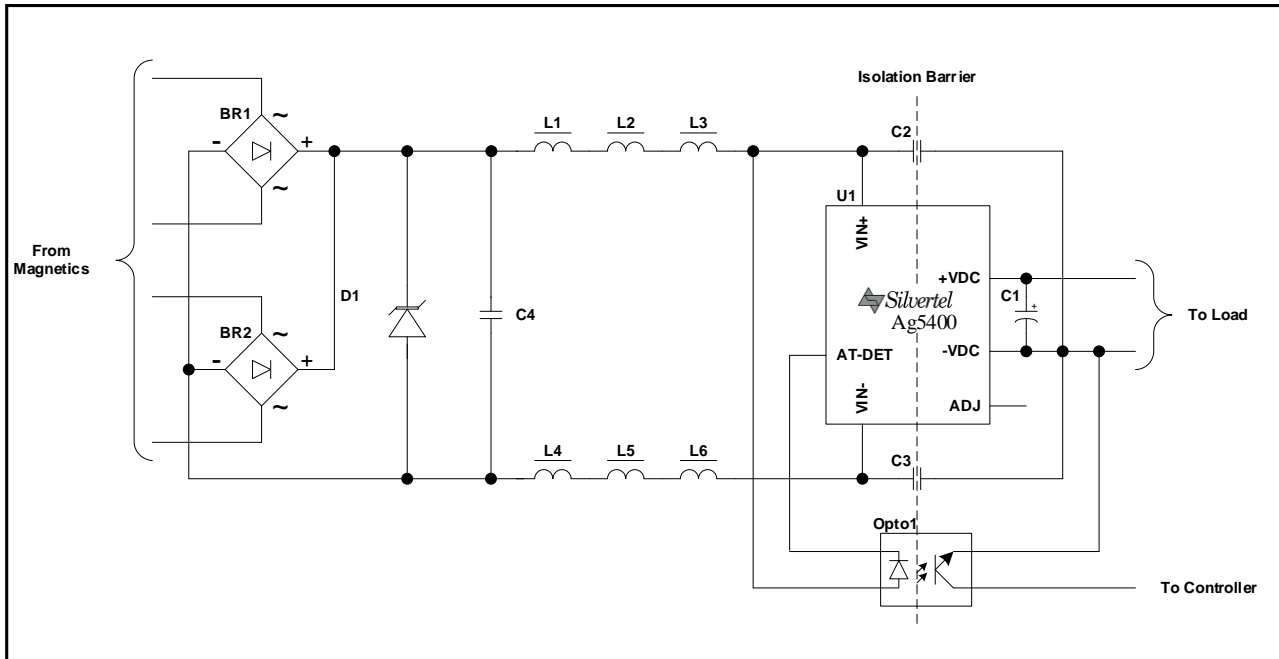

Figure 12: Isolation Barrier

7 EMC

The Ag5400 has been designed to pass EN55032 Class B, however the Ag5400 will only be one component within the system so we would always advise that provisions are put in place in case further noise reductions are needed. From our experience we would recommend an inexpensive but effective solution to reduce emissions as shown in Figure 13, for more details please see ANX-POE-EMI-Considerations.



D1 = SMAJ58A, L1 – L6 = MPZ2012S102A, C1 = 470µF 16V, Opto1 = KCP357NT, C2 & C3 = 4.7nF 2000V, C4=68nF 250V,

Figure 13: Typical Connection Diagram

8 Electrical Characteristics

8.1 Absolute Maximum Ratings

| | Parameter | Symbol | Min | Max | Units |
|---|---------------------|----------|------|------|-------|
| 1 | DC Supply Voltage | V_{CC} | -0.3 | 60 | V |
| 2 | Storage Temperature | T_S | -40 | +100 | °C |

Note : Exceeding the above ratings may cause permanent damage to the product. Functional operation under these conditions is not implied. Maximum ratings assume free airflow.

8.2 Recommended Operating Conditions

| | Parameter | Symbol | Min | Typ | Max | Units |
|---|-----------------------------------|------------|-----------------|-----|------|---------|
| 1 | Input Supply Voltage | V_{IN} | 36 ¹ | 50 | 57 | V |
| 2 | Input Under Voltage Lockout | V_{LOCK} | 33 | | 37 | V |
| 3 | Operating Temperature | T_{OP} | -40 | 25 | 85 | Ta / °C |
| 4 | Output capacitance | Ag5405 | 470 | 470 | 1000 | μF |
| | | Ag5412 | 220 | 470 | 1000 | |
| | | Ag5424 | 220 | 220 | 470 | |
| 5 | Output Capacitor ESR ² | C_{ESR} | | | 300 | mΩ |

Note 1: With minimum load

Note 2: At 100kHz

8.3 DC Electrical Characteristics

| | DC Characteristic | | Sym | Min | Typ ¹ | Max | Units | Comments |
|---|--|--------|--------------------|------|------------------|------|-------------------|-----------------------|
| 1 | Nominal Output Voltage | Ag5405 | +V _{OUT} | 4.75 | 5 | 5.25 | V | |
| | | Ag5412 | | 11.5 | 12 | 12.5 | | |
| | | Ag5424 | | 23.3 | 24 | 24.8 | | |
| 2 | Continuous Current output ² | Ag5405 | I _{LOAD} | | | 5.1 | A | |
| | | Ag5412 | | | | 2.5 | | |
| | | Ag5424 | | | | 1.25 | | |
| 3 | Line Regulation | | V _{LINE1} | | 0.1 | | % | @ 50% load |
| 4 | Load Regulation | | V _{LOAD1} | | 0.2 | | % | @ 57V _{in} |
| 5 | Ripple and Noise | Ag5405 | V _{RN} | | 40 | | mV _{p-p} | @ Max load |
| | | Ag5412 | | | 41 | | | |
| | | Ag5424 | | | 42 | | | |
| 6 | Minimum Load | | I _{MIN} | 0 | | | mA | |
| 7 | Short-Circuit Duration | | T _{SC} | | | ∞ | sec | Continuous @ 25 °C |
| 8 | Peak Efficiency ² | Ag5405 | EFF | | 91.5 | | % | @ 42.5V _{in} |
| | | Ag5412 | | | 93.3 | | | @ 44V _{in} |
| | | Ag5424 | | | 92.6 | | | @ 42.5V _{in} |
| 9 | Isolation Voltage (I/O) | | V _{ISO} | | | 1500 | V _{PK} | Impulse Test |

Note 1: Typical figures are at 25°C with a nominal output voltage with 57V supply with a 470µF output capacitor fitted and are for design aid only. Not Guaranteed.

Note 2: Minimum 42.5V_{in} for maximum output at 25°C



CODICO GmbH
 Zwingenstraße 6-8, 2380 Perchtoldsdorf, Austria
 Telefon: +43 1 86 305-0, Fax: +43 1 86 305-5000
 e-mail: office@codico.com, www.codico.com
 FN 436940i, Landesgericht Wr. Neustadt

Zertifiziert nach ISO 9001:2015

9 Package

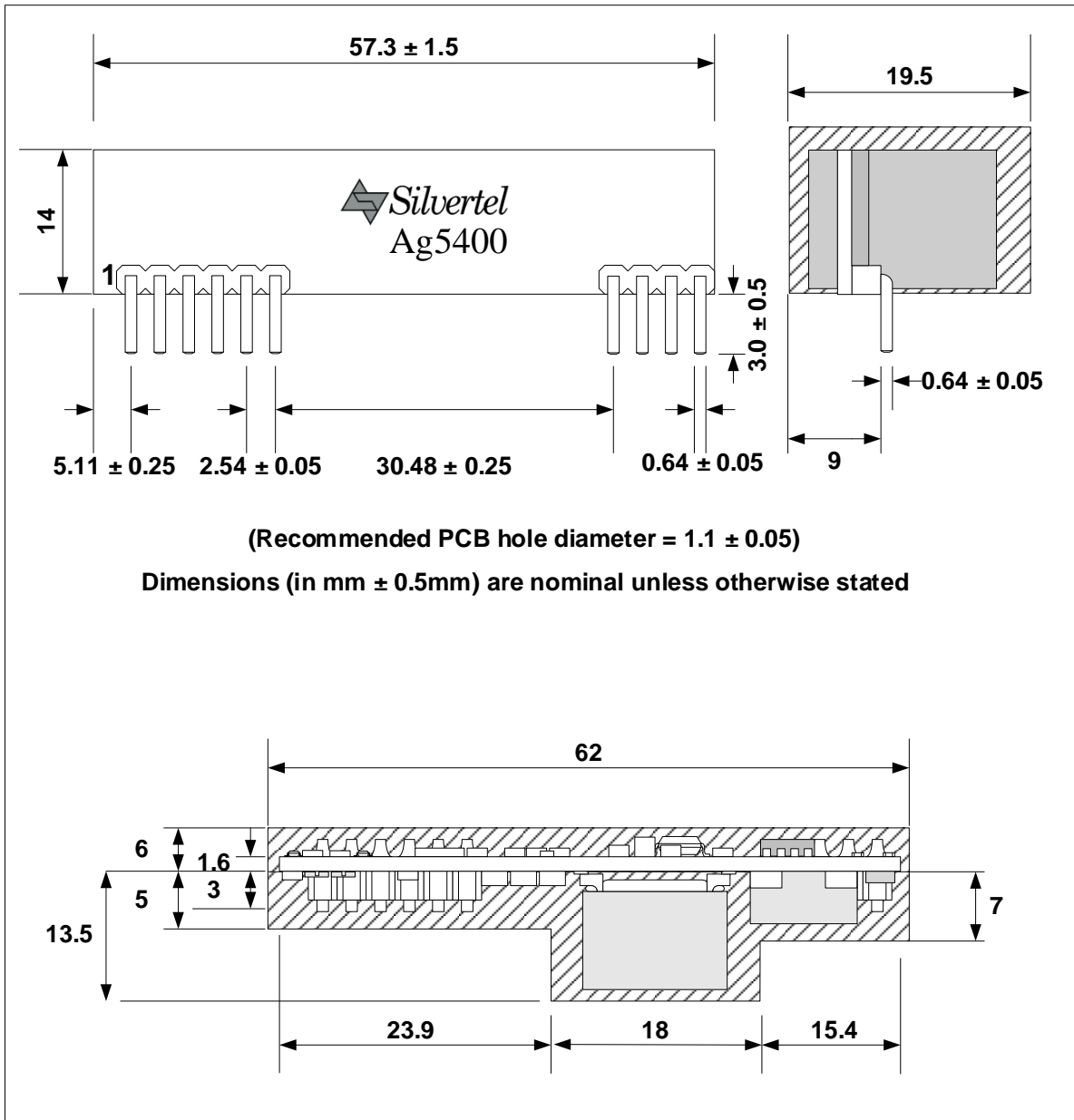

Component Keep Out

Figure 14: Package Dimensions

Information published in this datasheet is believed to be correct and accurate. Silver Telecom assumes no liability for errors which may occur or for liability otherwise arising out of use of this information or infringement of patents which may occur as a result of such use. No license is granted by this document under patents owned by Silver Telecom or licensed from third parties by Silver Telecom. The products, their specification and information appearing in this document are subject to change by Silver Telecom without notice.