

YELLOW beet is a universal powerline module based on Qualcomm's QCA7005 chip supporting HomePlug GreenPHY standard. There are 3 different versions of the module and despite primary focus on e-mobility (EVSE and PEV) it also perfectly fits for smart grid, smart meter, IoT and other long-range communication applications. All modules come with extended industrial temperature range making it suitable even for high-end automotive applications. Low noise floor and optimized line coupling circuitry with custom components including 1:1:1 and 1:4:5 ratio transformers and 4 kV overvoltage protection.

*\*Available for purchase from CODICO GmbH*

## Quick specs

- Based on QCA7005
- Extended industrial temperature range (up to 105 °C)
- SPI and GPIO interfaces to QCA7005
- Modified powerline chipset QFN package for easy optical inspection
- Single side, SMD module
- Comes in 3 different configurations: PEV (plug-in electric vehicle), EVSE (electric vehicle supply equipment) and EN50561-1 (long range powerline communication)
- Includes line coupling for e-mobility and long-range communication applications

# Table of Contents

---

<b>1. Features</b>	<b>3</b>
<hr/>	
<b>2. Block diagram</b>	<b>3</b>
<hr/>	
<b>3. Operating conditions</b>	<b>4</b>
<hr/>	
<b>4. Module pinout and pin description</b>	<b>5</b>
<hr/>	
<b>5. Powerline and zero-cross connection</b>	<b>9</b>
<hr/>	
<b>6. Power supply reference design</b>	<b>10</b>
<hr/>	
<b>7. Layout design rules</b>	<b>11</b>
<hr/>	
<b>8. Module marking information</b>	<b>12</b>
<hr/>	
<b>9. Mechanical characteristics</b>	<b>13</b>
<hr/>	
<b>10. Reflow profile information</b>	<b>16</b>
<hr/>	
<b>11. Evaluation boards</b>	<b>17</b>
<hr/>	
<b>12. Packaging and ordering information</b>	<b>18</b>
<hr/>	
<b>13. Document revision history</b>	<b>20</b>

# 1. Features

TABLE 1-1. YELLOW BEET FEATURES

	YELLOW beet H	YELLOW beet E	YELLOW beet P
Powerline chip	QCA7005		
Firmware version	HomePlug GreenPHY FW v1.2.5-00		
Configuration (PIB)	EN 50561-1	EVSE	PEV
Host interface	SPI (default)		
Power supply	3.3V		
Power consumption	1 W (at 25° C)		
Mains coupling on board	Yes	Yes, for ZC (zero-cross) only	No
Max data rate	9.8 Mbps PHY rate / 4.7 Mbps UDP data rate		
Max distance	300 meters	According to ISO/IEC 15118-3	
Temperature range	-40° C to +105° C (board temperature)		
Size	59 x 23 x 4 mm (up to 9 mm including transformer height)		
Weight	6.3 ±0.1 g	5.8 ±0.1 g	5.6 ±0.1 g
Applications	IoT, home control, appliances, smart plugs, building and industrial automation, smart grid, electric meters, water heaters	Electric vehicle charging stations	Plug-in electric vehicles (on board)
Ordering number	YELLOW-BEET-H	YELLOW-BEET-E	YELLOW-BEET-P

# 2. Block diagram

FIGURE 2-1. YELLOW BEET MODULE BLOCK DIAGRAM

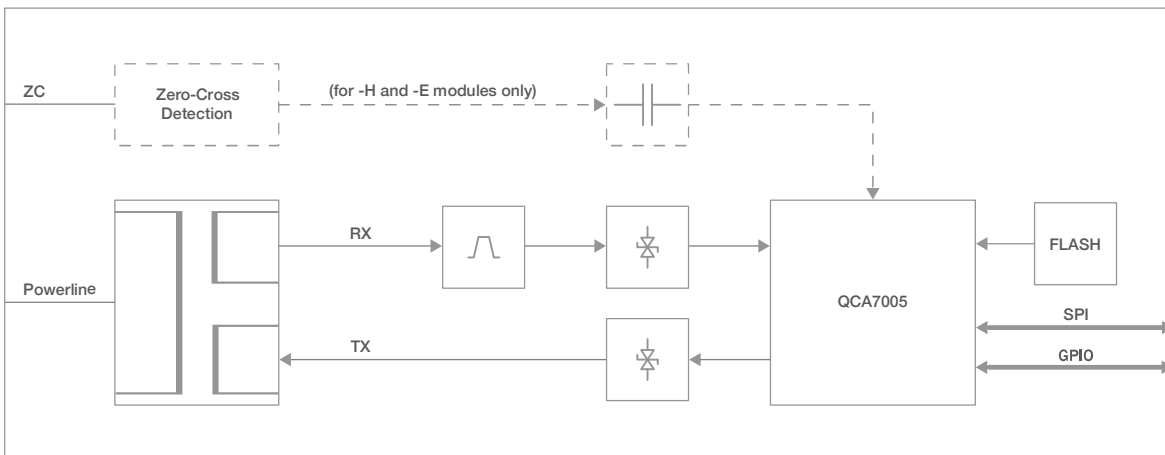

### 3. Operating conditions

**TABLE 3-1. STANDARD OPERATING CONDITIONS**

Parameter	Min	Typical	Max	Units
VDD, SERIAL, GPIO	3.13	3.3	3.46	V
Operating temperature (board)	-40	-	105	°C
Ambient temperature	-40	-	85	°C
Control Pilot voltage (CP)	-12	-	+12	V
AC mains voltage (ZC_LINE, AC_LINE)	-	240 120	-	V <sub>RMS</sub>

**TABLE 3-2. ABSOLUTE MAXIMUM RATINGS**

Parameter	Min	Typical	Max	Units
VDD, SERIAL, GPIO	-0.3	-	3.6	V
Operating temperature (board)	-40	-	105	°C
Storage temperature	-40	-	150	°C
RESETN active pulse duration	100	-	-	us
Control Pilot voltage (CP)	-13	-	+13	V
AC mains voltage (ZC_LINE, AC_LINE)	112	-	265	V <sub>RMS</sub>

**TABLE 3-3. YELLOW BEET MODULE POWER CONSUMPTION (+25°C AMBIENT TEMPERATURE)**

Operation mode	Typical	Units
Transmit Mode	1000	mW
Receive Mode	700	mW
Idle Mode (no communication)	330	mW
RESETN Pin Active Mode	200	mW
Sleep Mode (power saving mode)	100	mW

**NOTE:** Operation at maximum temperature limit may increase power consumption up to 25%.

YELLOW beet power supply should have extra 25% power margin and be capable of providing power up to 1600 mW

**TABLE 3-4. ZERO-CROSS DETECTOR INPUT SIGNAL SPECIFICATION**

Parameter	Min	Typical	Max	Units
AC mains frequency (F)	48.4 57.7	50 60	51.6 62.3	Hz

## 4. Module pinout and pin description

FIGURE 4-1. PIN ASSIGNMENTS (BOTTOM VIEW)



TABLE 4-1. PIN DESCRIPTION

Pin number	YELLOW beet H	YELLOW beet E	YELLOW beet P	Type	Description
1		GND		-	Ground connection
2		GND		-	Ground connection
3		GND		-	Ground connection
4		GND		-	Ground connection
5		GND		-	Ground connection
6		GND		-	Ground connection
7		GND		-	Ground connection
8		VCC		-	3.3V power supply
9		GND		-	Ground connection
10		GND		-	Ground connection
11		GND		-	Ground connection
12		GPIO_0		I/O	PU (10 kOhm) - boot from Flash
13		GPIO_1		I/O	PD (10 kOhm) - required for QCA7005
14		GPIO_2		I/O	PU (10 kOhm) - SPI burst mode
15		GPIO_3		I/O	Input (push button)
16		RESETN		I	Reset (active low)
17		GND		-	Ground connection
18		SERIAL_IO_4		I	MOSI (default)

**TABLE 4-1. PIN DESCRIPTION (CONTINUATION)**

Pin number	YELLOW beet H	YELLOW beet E	YELLOW beet P	Type	Description
19		SERIAL_IO_3		O	MISO (default)
20		SERIAL_IO_2		I	SPI CS (default)
21		SERIAL_IO_1		I	SPI CLK (default)
22		SERIAL_IO_0		O	SPI INT (default)
23		GND		-	Ground connection
24		GND		-	Ground connection
25		NC		-	-
26		NC		-	-
27	AC_NEUTRAL	CP (Control Pilot)			Powerline pin 1
28	AC_LINE	PE (Protective Earth)			Powerline pin 2
29	ZC_LINE (Zero-Cross input)	NC			Zero-cross pin 1
30		NC		-	-
31	ZC_NEUTRAL (Zero-Cross neutral)	NC			Zero-cross pin 2
32		THERMAL PAD (GND)		-	Thermal pad with a connection to Ground plane

**NOTE:** Thermal pad shall have a good connection to the Ground plane for a better heat dissipation. It is recommended to have 25 vias 0.3 mm in diameter (formed as a square of 5x5 vias) to a Ground layer which spreads heat all along the PCB.

**TABLE 4-2. BOOT STRAP GPIO CONFIGURATION**

GPIO number	Function	PU (pull-up)	PD (pull-down)
GPIO_0	Boot source	Flash	Host
GPIO_1	Host interface	-	SPI slave
GPIO_2	SPI slave mode	Burst	Legacy
GPIO_3	None	-	-

**NOTE:** PU/PD resistor values 10 kOhm in all cases.

There are PU/PD resistors installed on the module already. GPIO\_0 and GPIO\_2 are pulled-up (PU) and GPIO\_1 is pulled-down (PD).

**TABLE 4-3. GPIO FUNCTIONS (AFTER BOOT UP)**

GPIO number	Type	Function
GPIO_0	Output	LED: PLC link and simple connect statuses
GPIO_1	Output	LED: PLC RX/ TX status
GPIO_2	Output	LED: throughput indication
GPIO_3	Input	Push button: - Simple connect: 0.5 to 3s hold time - NMK randomization: 5 to 8s hold time - Factory defaults: 10 to 15s hold time

**NOTE:** All above specified settings are for QCA7005 FW v1.2.5-00.

**FIGURE 4-2. GPIO LED SCHEMATIC PROPOSAL (GPIO\_0, GPIO\_1, GPIO\_2)**

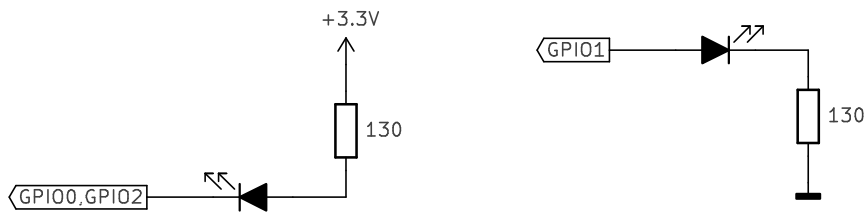

**NOTE:** Typically LEDs are only required for Home control applications (YELLOW beet H module)

**FIGURE 4-3. PUSH BUTTON SCHEMATIC PROPOSAL (GPIO\_3)**

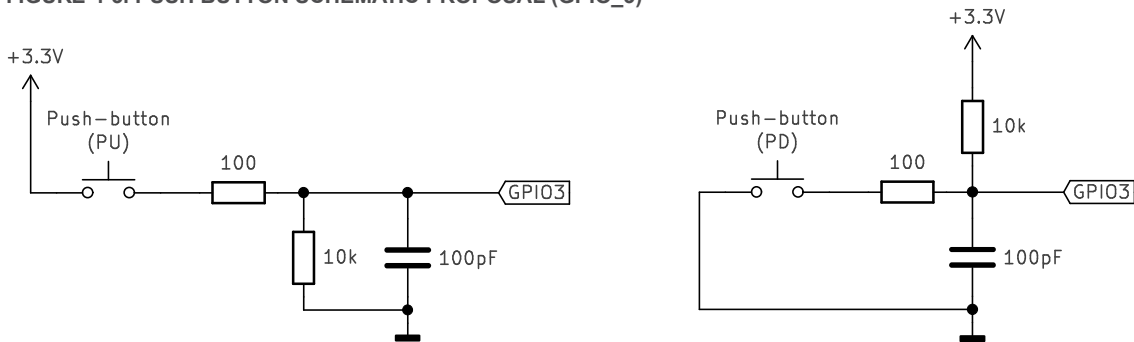

**NOTE:** Typically Push-button is only required for Home control applications (YELLOW beet H module)

**TABLE 4-5. SERIAL CONFIGURATION OPTIONS**

	SPI (default)	UART
SERIAL_IO_0	Interrupt	
SERIAL_IO_1	CLK	
SERIAL_IO_2	CS	
SERIAL_IO_3	MISO	TXD
SERIAL_IO_4	MOSI	RXD

**NOTE:** SPI interface is a default and only recommended interface. In the bootloader the only available interface is SPI.

**TABLE 4-6. UART SETTINGS**

Setting	Value
Maximum recommended baud rate	57600
Data bits	8
Parity	None
Stop bits	1
Flow control	None

QCA7005 supports SPI Mode 3 (Motorola-SPI standard), where both CPOL (clock polarity) and CPHA (clock phase) are set to 1 (clock cycle idles at 1 and consists of a pulse of 0, data valid at raising edge of clock). QCA7005's maximum slave SPI clock frequency is 12 MHz.

When an out-of-sync condition happens, the SPI host needs to reset QCA7005 in order to sync up and go back to the normal operation.

The preferred mode of SPI operation is Burst Mode to eliminate external RESET operation.

To reset QCA7005, the SPI host can issue register write to the bit[6] of SPI-CONFIG register.

## Software resources

QCA7000/5 SPI driver is a part of Linux kernel since v3.18. QCA7000/5 driver converts Ethernet frames between Ethernet and SPI interfaces using HAL drivers.

Use 8devices wiki to find getting started instruction and other materials:

<https://www.8devices.com/wiki/yellow-beet>

YELLOW beet module as well as other HomePlug AV/GreenPHY devices could be configured and controlled using a set of command line tools open-plc-utilities. Source codes of open-plc-utilities and manuals could be found on Github repository:

<https://github.com/qca/open-plc-utils>

## Zero-cross detection in various applications

Zero-cross detection has to be used in all applications with communication over AC mains or when module's power supply is powered from AC mains. Two or more HomePlug AV/GreenPHY logical networks can only coexist when zero-cross detection circuit is implemented.

Use of zero-cross detection is mandatory in all types of EVSE applications (including AC and DC charging stations). Reference circuits for zero-cross detection are shown in Chapter 5.



## 5. Powerline and zero-cross connection

**YELLOW beet H** module is designed for connection (pins 27 and 28) to AC or DC power lines with voltage up to 250Vrms. Circuit protection (such as Varistor/MOV, Fuse) is not included on the YELLOW beet module and has to be considered and added extra. Junction capacitance of circuit protection has to be less than 10pF.

**YELLOW beet E/P** modules are designed for use on CP/PE (Control Pilot / Protective Earth, pins 27 and 28) in e-mobility applications and tolerant to +12/-12V PWM 1kHz signal.

PLC signal surge protection (3V rated TVS diode with 3pF junction capacitance) is implemented on the module. Surge protection for CP for PWM 1kHz related circuit is highly recommended (use 12V rated TVS diode with junction capacitance less than 10pF, e.g. GBLC12C).

Zero-cross circuit has to be connected to AC mains (YELLOW beet H and E modules, pins 29 and 31) with voltage up to 250Vrms. Circuit and surge protection (such as Varistor/MOV, Fuse, TVS diode) is not included on the YELLOW beet module, it has to be considered and added extra.

For **YELLOW beet H**, when powerline and zero-cross pins are connected to AC mains it is recommended to implement LISN (line impedance stabilization network) circuit (Figure 5-1) in front of zero-cross detector.

**FIGURE 5-1. LISN (LINE IMPEDANCE STABILIZATION NETWORK) CIRCUIT FOR ZERO-CROSS DETECTOR**

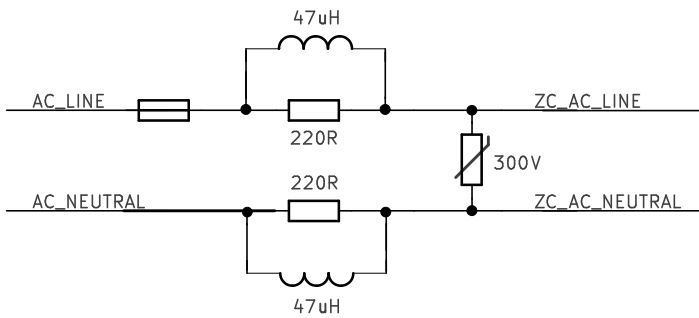

## 6. Power supply reference design

On the Figure 6-1 there is a reference design schematics for YELLOW beet power supply.

**FIGURE 6-1. YELLOW BEET POWER SUPPLY RECOMMENDATION**

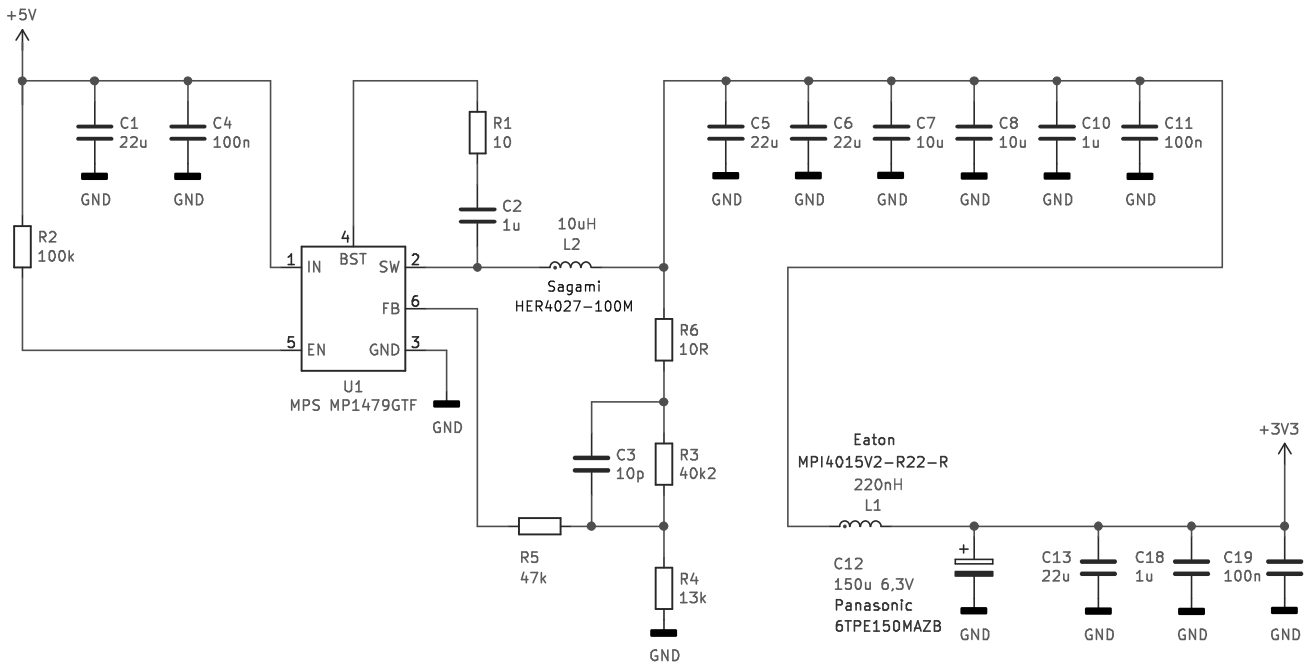

The recommended design of +3.3V power supply for YELLOW beet module based on MP1479 has very low level of noise and ripple. The nominal input voltage of the power supply is +5V DC, however it also can work in a broad input voltage range from +4.5V to 15V DC.

When +5V input voltage is used, 22uF C1 should be MLCC. In case input voltage is higher (e.g. +12V), MLCC is not sufficient because of DC bias derating, therefore 22uF C1 should be changed to Tantal Polymer capacitor and in addition 1uF C1a MLCC should be added in parallel to C1 for low ESR (use X7R type capacitor).

**Note:** Circuit protection and EMI filter for DC-DC power supply input are not shown on Figure 6-1 and if required, has to be implemented extra.

## 7. Layout design rules

1. YELLOW beet module must not be placed near components that carry power supply switching currents.
2. Absolutely no digital traces are allowed to traverse area underneath YELLOW beet module on any layer. Electromagnetic pulses (EMP) of the trace currents will be induced onto the RX and TX traces.
3. All inductors on the board must be shielded. Put Ground in layout underneath of the inductors. Connect the start of the winding to the switching node.
4. Place ground guards against any currents passing under the analog section on any PCB layer.
5. Keep all DC-DC switching regulators and power planes well away from YELLOW beet module.
6. Thermal pad shall have a good connection to the Ground plane for better heat dissipation. It is highly recommended to have 25 vias 0.3 mm in diameter (formed as a square of 5x5 vias) to a Ground layer which spreads heat all along the PCB. But do not cover the whole copper area underneath of thermal pad with a soldering paste, make sections as it is shown on Soldering paste footprint on page 15.
7. Length of SPI interface wires should be not longer than 10 cm.
8. Place the high-current paths of power supply (Ground, input voltage, switch output) absolutely close to the switching regulator with short, direct, and wide traces.
9. Place the input capacitor as close to the input voltage of power supply and Ground as possible (recommended to use 1 mm width traces) with a low impedance connection to minimize the antenna loop area.
10. Keep the switching node of power supply switching regulator IC small. Route switch output away from sensitive analog areas, such as feedback line.
11. Place the external feedback resistors as close to Feedback pin of switching regulator as possible. Keep all feedback connections short and direct. Keep away from the switching node.
12. It is recommended to place the filter components of power supply on the bottom side, shielded from the noisy switching circuits by the Ground plane.
13. Distance is required between the noisy source, filter components, and the post filter circuits of power supply. Shielding can replace distance.

## 8. Module marking information



Each module is marked with a label containing the following data:

1. Ordering code
2. QCA7005 MAC Address (contains no separator, OUI C49300)
3. Serial Number in a format PWL200VWWYYNNNNNN, where:
  - PWL200 - product code for YELLOW beet modules
  - V - version of module (1 for -H, 2 for -E, 3 for -P)
  - WWYY - date code as a calendar week of production followed by a year
  - NNNNNN - serial number in a production lot
4. QR-code containing MAC Address
5. Additionally each label contains 8Devices logo which also indicates pin 1 position

# 9. Mechanical characteristics

## YELLOW beet H mechanical characteristics

TOP VIEW

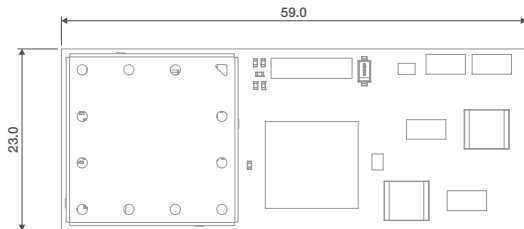

PERSPECTIVE VIEW

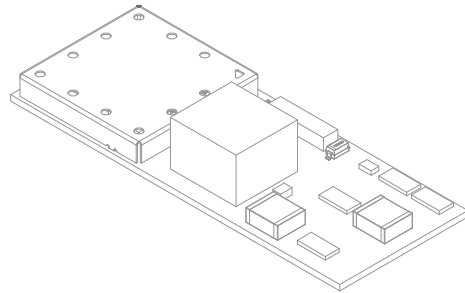

SIDE VIEW

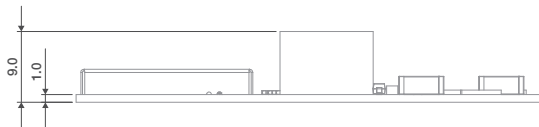

BOTTOM VIEW

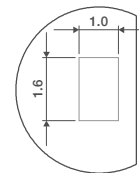
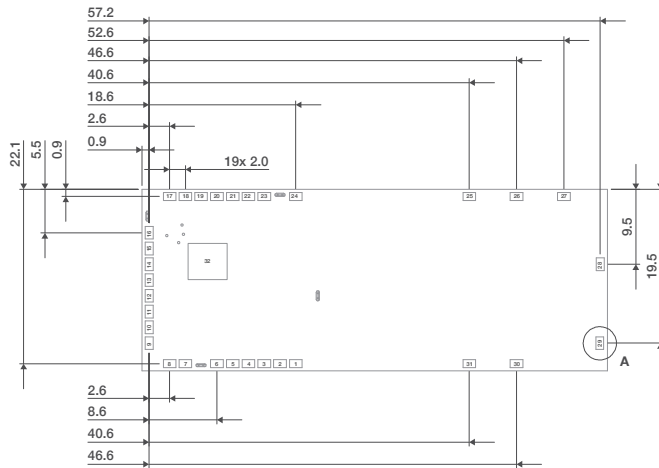

DETAIL A

# YELLOW beet E/P mechanical characteristics

**TOP VIEW**

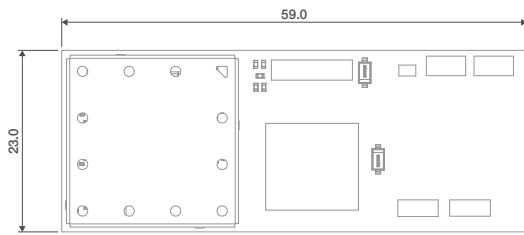

**PERSPECTIVE VIEW**

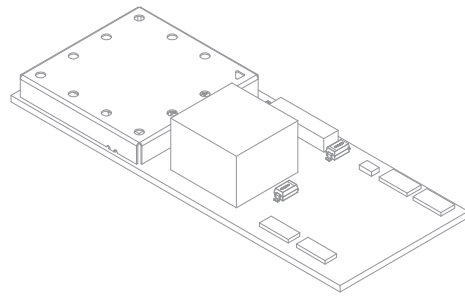

**SIDE VIEW**

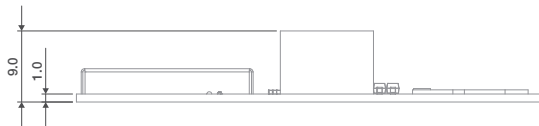

**BOTTOM VIEW**

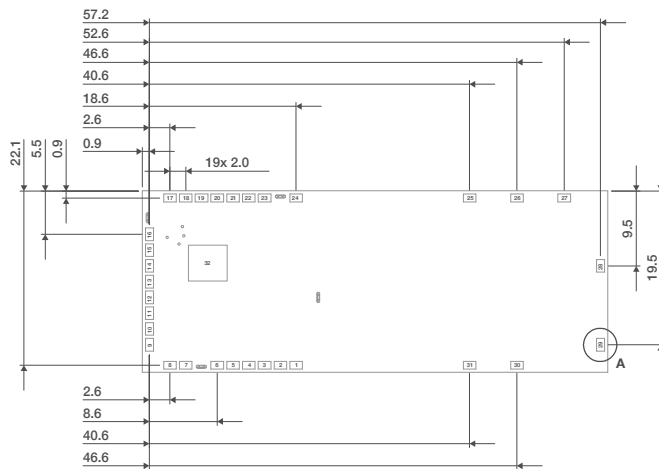

**DETAIL A**

## PCB footprint

### TOP VIEW

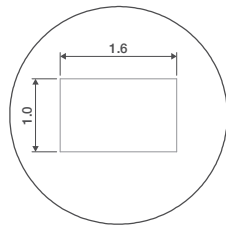
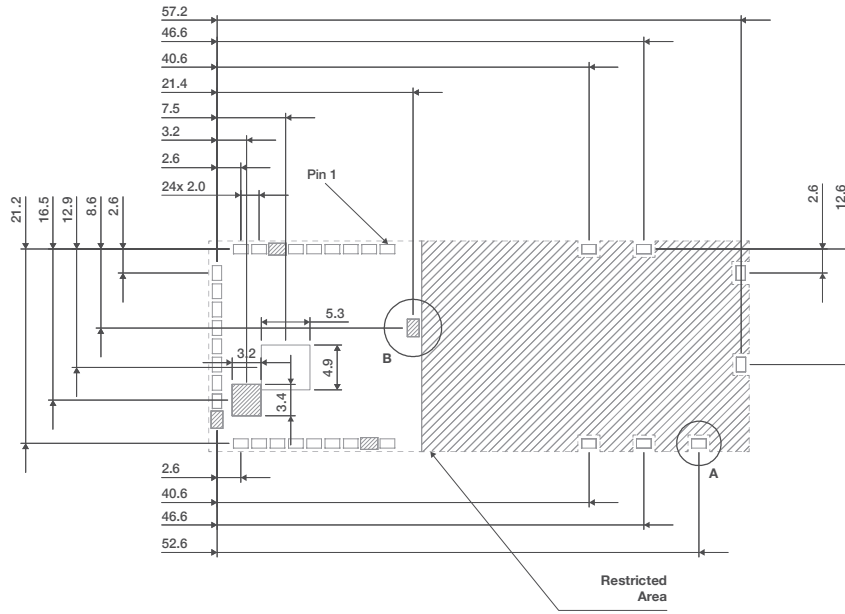

DETAIL A

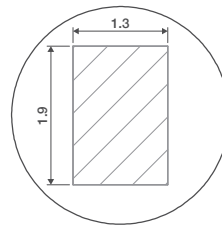

DETAIL B

## Soldering paste footprint

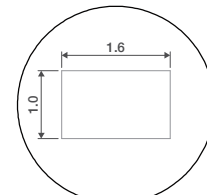

DETAIL C

## 10. Reflow profile information

### Reflow profile recommendation

Ramp up rate	3°C/second max
Maximum time maintained above 217°C	120 seconds
Peak temperature	250°C
Maximum time within 5°C of peak temperature	20 seconds
Ramp down rate	6°C/second max

### Reflow profile

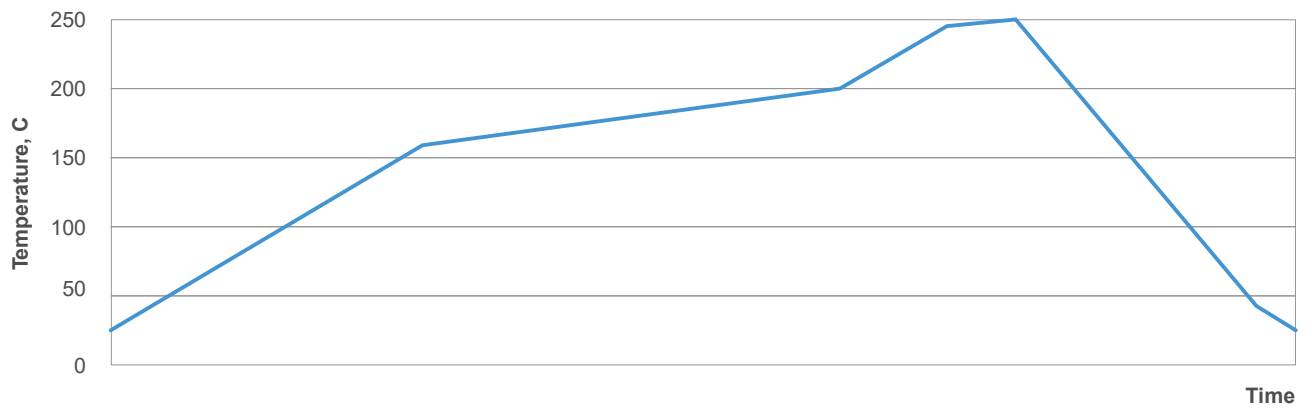



## 11. Evaluation boards

In order to evaluate HomePlug AV/GreenPHY PLC technology and RED/YELLOW beet modules operation in particular, there is a set of evaluation boards available:

**CARRIER board** - contains RED beet module configured for one of the applications: Home Control, Automotive EVSE and PEV sides. It comes with line coupling for e-mobility applications or for working on mains. A standard 20-pin header connector is available for connection to an external MCU via SPI. For more details please refer to CARRIER board datasheet.

**COMM board** - contains STM32F745 MCU which has QCA7005 driver implemented and depends on the embedded firmware, it can:

- operate as interface converter between QCA7005 SPI and a number of interfaces available on STM32 MCU (including Ethernet and USB)
- support SLAC for automotive applications (EVSE and PEV)
- run ISO/IEC 15118 software stack for e-mobility charging applications
- be used for ISO/IEC 15118 stack implementation development base on Sevenstax SDK

Communication board has Ethernet, USB, CAN, SPI and UART interfaces available.  
For more information please refer to COMM board datasheet.

CARRIER and COMM boards could be used individually or as a joint set of evaluation boards.

## 12. Packaging and ordering information

YELLOW beet modules are packed into trays. Each tray fits 24 modules. Every 5 trays are vacuum sealed and one standard packing box contains 600 modules.

FIGURE 12-1. YELLOW BEET TRAY DIMENSIONS

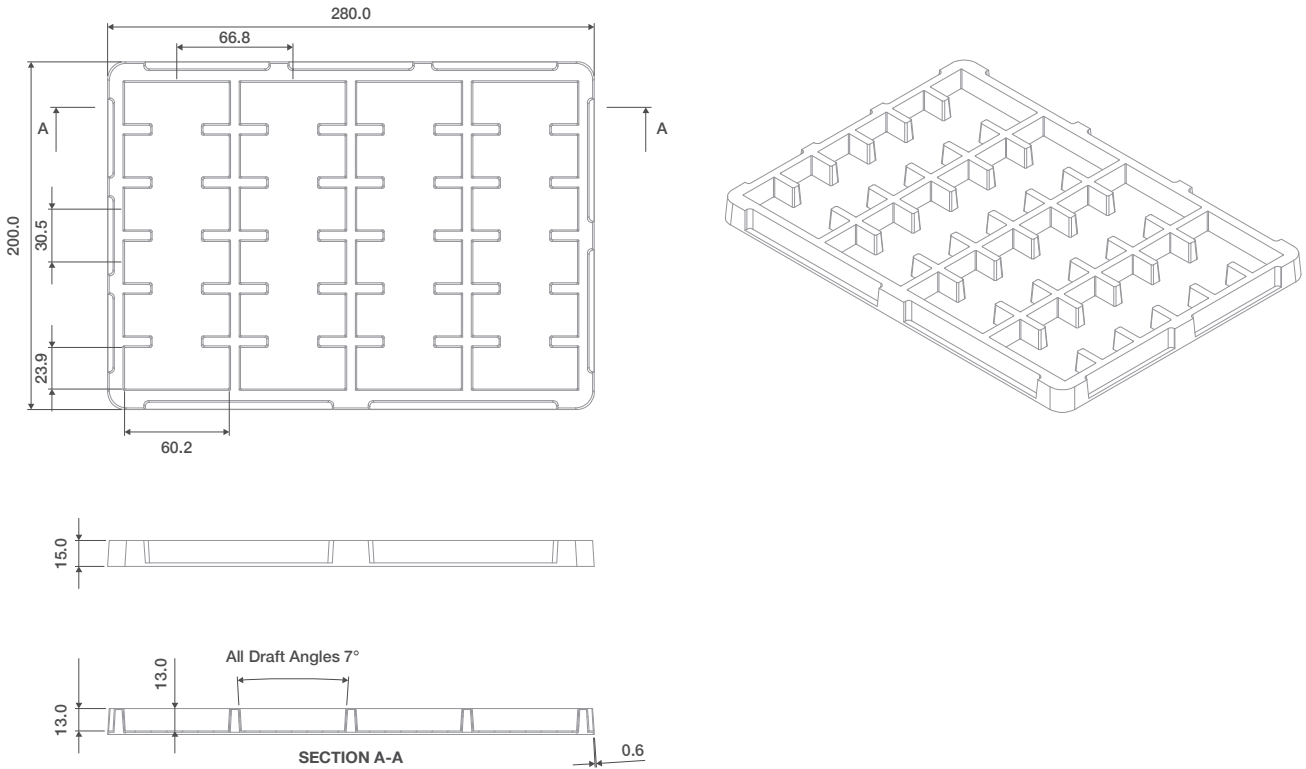
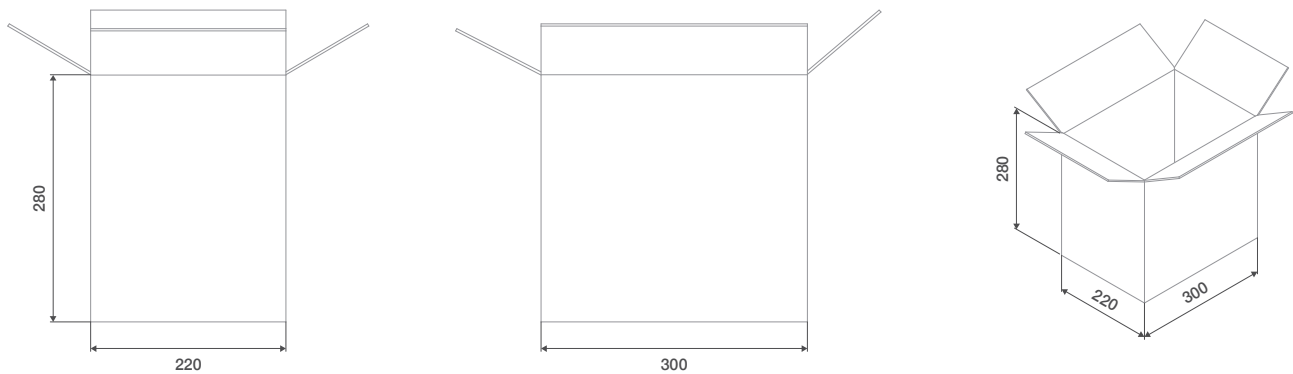

FIGURE 12-2. STANDARD PACKING BOX DIMENSIONS



**TABLE 12-1. ORDERING PART NUMBERS**

Part number	Description
YELLOW-BEET-H #292201	YELLOW beet module for home control
YELLOW-BEET-E #292202	YELLOW beet module for EVSE (Electric vehicle supply equipment)
YELLOW-BEET-P #292203	YELLOW beet module for PEV (Plug-in electric vehicle)
CARRIER-BOARD-H #292204	Carrier board for development and testing with line coupling and SPI interface for external MCU with home control configuration
CARRIER-BOARD-E #295015	Carrier board for development and testing with line coupling and SPI interface for external MCU with EVSE configuration
CARRIER-BOARD-P #295016	Carrier board for development and testing with line coupling and SPI interface for external MCU with PEV configuration
COMM-BOARD-S #292205	Interface converter and ISO/IEC 15118-3 communication board is based on STM32F745 microcontroller for e-mobility applications with transparent or SLAC bridging software.
COMM-BOARD-I #295305	Interface converter and ISO/IEC 15118-3 communication board is based on STM32F745 microcontroller for e-mobility applications with ISO/IEC 15118 software stack.
COMM-BOARD-O #295307	Interface converter and ISO/IEC 15118-3 communication board is based on STM32F745 microcontroller for e-mobility applications with open SDK.

More PEV / EVSE - configured eMobility related products can be found in CODICO Sample Shop:

<https://www.codico.com/en/products/powerline-communication>

## 13. Document revision history

Revision	Revision Date	Description
0.1	2020.01.06	First draft
0.2	2020.02.20	Minor corrections, LED/ push-button circuits modification
0.3	2020.02.21	Circuit of DC-DC was replaced
1.0	2020.02.24	Figure 2-1 and chapter 7 were updated
1.1	2020.02.24	Figure 2-1 and chapter 7 were updated
1.11	2020.03.04	Layout recommendation added + minor corrections
1.12	2020.06.09	Start of production release (total document revision)
1.14	2020.06.15	Formatting and grammar correction Layout design rules added
1.15	2020.06.17	Figure 2-1 correction
1.16	2020.06.24	Cover image actualized. Table 1-1, weight added. Table 3-3, power consumption added. Chapter 5 added, powerline and ZC connection, LISN circuit. Legal statement added.
1.17	2020.07.03	Power supply and ZC notes added, soldering paste footprint corrected
1.18	2020.10.01	Minor corrections
1.19	2020.11.27	RESETN timing, CP, ZC_LINE, AC_LINE voltage parameters added in Chapter 3.
1.20	2020.12.11	Ordering information correction

\*\*\* The confidential information is provided "as is". The discloser makes no representations or warranties, express or implied, with respect to the information, and disclaims all warranties including, without limitation, the warranties of merchantability, and fitness for a particular purpose. \*\*\*