

THINKING ELECTRONIC INDUSTRIAL CO., LTD.

HEAD OFFICE: 8F-1, No.93, Ta-Shun 1st Rd., Kaohsiung, Taiwan
 TEL: 886-7-5577660 FAX: 886-7-5570560

MANUFACTURING SITE

- KAOHSIUNG FACTORY: No.51, Kaifa Road, Nantze Export Processing Zone,
 Kaohsiung City 81170, Taiwan
 TEL: 886-7-9616668 FAX: 886-7-9616698
- CHANGZHOU FACTORY: No.82,Renmin Mid Rd.,WuJin High&New-Tech Industrial
 Development Zone,ChangZhou,JiangSu,China
 TEL:86-519-86578999 FAX:86-519-86558643
- DONG GUAN FACTORY: Chiao-Tou Tsun, Sha-Tao Hsiang, Chang-An Town,
 Dong-Guan City 523863, Guangdong, China
 TEL:86-769-85542016 FAX:86-769-85546890
- YICHANG FACTORY: No. 283 Xiaoting Avenue, Xiaoting Dist., Yichang
 City 443007, Hubei, China
 TEL:86-717-6510010 FAX:86-717-6511430

**SPECIFICATION FOR APPROVAL**

CUSTOMER	Codico
CERTIFIED MODEL/TYPE	TPM1S471P115
PART NO.	TPM1S471P115RT (RoHS+HF)
APPLICATION	
CUSTOMER P/N	
ISSUE DATE	Mar. 11, 2016
REV. NO.	
REV. DATE	

FOR CUSTOMER APPROVAL	CHECKED BY
	<i>Shu Ling Fu</i>
	APPROVED BY
	<i>Chun Chu Tu</i>





REVISED RECORD SHEET

REV. NO	REV. DATE	REVISED CONTENT



INDEX	Page
■ Part Number Code	1
■ Structure and Dimensions	2
■ Electrical Characteristics	2
■ Reliability	3
■ Soldering Recommendation	4
■ Recommended Soldering Pad Dimensions	5
■ RoHS Compliant Declaration	5
■ Warehouse Storage Conditions of Products	5
■ Packaging	6
■ Safety Approvals & Certificates & Test Report	7
■ R-T Characteristic Curve	8

Part Number Code

Example :

TPM **1** **S** **471** **P** **115** **R** **T**
(1) (2) (3) (4) (5) (6) (7) (8)

No.	Item	Digit	Specification
(1)	Product Type	TPM	Thinking CPTC thermistor TPM type
(2)	Size (EIA)	1	0603
(3)	Type Series	S	Sensing series
(4)	Zero Power Resistance at 25°C	471	$47 \times 10^1 = 470\Omega$
(5)	Tolerance of R_{25}	P	$\pm 50\%$
(6)	Sensing Temperature	115	$T_s = 115^\circ\text{C}$
(7)	Packaging	R	Reel
(8)	Optional Suffix	T	Dual Sensing Temperature Product

Structure and Dimensions

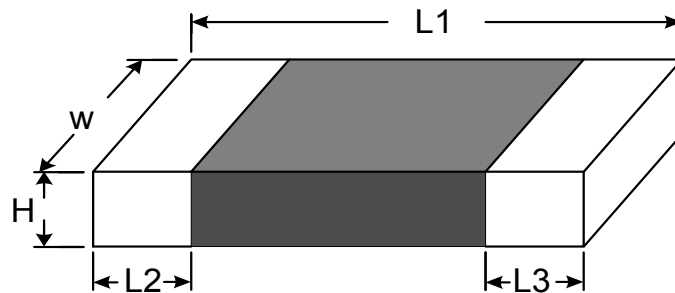

(unit : mm)

L1	W	H max.	L2 and L3
1.60±0.15	0.80±0.15	0.95	0.40±0.20

Electrical Characteristics

Part No.	Zero Power Resistance at 25°C	Sensing Temp.1 @ 4.7KΩ	Sensing Temp.2 @ 47KΩ	Max. Voltage	Operating Temperature Range
	R ₂₅ (Ω)	Ts1 (°C)	Ts2 (°C)	Vmax. (V _{DC})	(°C)
TPM1S471P115RT	470±50%	115±5	130±7	32	-25~+140

Reliability

Item	Standard	Test conditions / Methods	Specifications															
Bending Strength	IEC60068-2-21	Warp : 2mm ; Speed < 0.5mm/sec. Duration : 10 sec on PCB. 	No visible damage $ \Delta R_{25}/R_{25} \leq 10\%$															
Damp Heat, Steady State	IEC 60068-2-78	40 ± 2 °C , 90 ~ 95% RH , 1000± 24 hrs	No visible damage $ \Delta R_{25}/R_{25} \leq 20\%$															
High Temp. Storage	IEC 60068-2-2	T _U ± 5 °C , 1000 ± 24 hrs	No visible damage $ \Delta R_{25}/R_{25} \leq 20\%$															
Low Temp. Storage	IEC 60068-2-1	T _L ± 3 °C , 1000 ± 24 hrs	No visible damage $ \Delta R_{25}/R_{25} \leq 20\%$															
Rapid Change of Temperature	IEC 60068-2-14	The conditions shown below shall be repeated 5 cycles on PCB <table border="1" style="margin-left: auto; margin-right: auto;"> <thead> <tr> <th>Step</th> <th>Temperature (°C)</th> <th>Period (minutes)</th> </tr> </thead> <tbody> <tr> <td>1</td> <td>-25± 5</td> <td>30 ± 3</td> </tr> <tr> <td>2</td> <td>Room temperature</td> <td>5 ± 3</td> </tr> <tr> <td>3</td> <td>150± 5</td> <td>30 ± 3</td> </tr> <tr> <td>4</td> <td>Room temperature</td> <td>5 ± 3</td> </tr> </tbody> </table>	Step	Temperature (°C)	Period (minutes)	1	-25± 5	30 ± 3	2	Room temperature	5 ± 3	3	150± 5	30 ± 3	4	Room temperature	5 ± 3	No visible damage $ \Delta R_{25}/R_{25} \leq 20\%$
Step	Temperature (°C)	Period (minutes)																
1	-25± 5	30 ± 3																
2	Room temperature	5 ± 3																
3	150± 5	30 ± 3																
4	Room temperature	5 ± 3																
High Temp. Load	IEC 60738-1 7.24.3	85 ± 5 °C , Vmax. , 1000 ± 24 hrs	No visible damage $ \Delta R_{25}/R_{25} \leq 20\%$															
Climatic Sequence	IEC 60738-1 7.22	a. T _U x 16 hrs b. 1st cycle : 40 °C 95 %RH x 24 hrs c. T _L x 2 hrs d. 5 cycles : 40°C 95% RH x 24 hrs / Cycle	No visible damage $ \Delta R_{25}/R_{25} \leq 20\%$															
Solderability	IEC 60068-2-58	245 ± 5 °C , 3 ± 0.3 sec	At least 95% of terminal electrode is covered by new solder															
Resistance to Soldering Heat	IEC 60068-2-58	8.1.2.2 Solder reflow method Preheating: 150~180°C ,60~120 secs. Peak temp.: 245~255°C , ≤20 secs. (reflow)	No visible damage $ \Delta R_{25}/R_{25} \leq 20\%$															

Note: T_L = Minimum operating temperature (°C)

T_U = Maximum operating temperature (°C)

Soldering Recommendation

■ IR-Reflow Soldering Profile

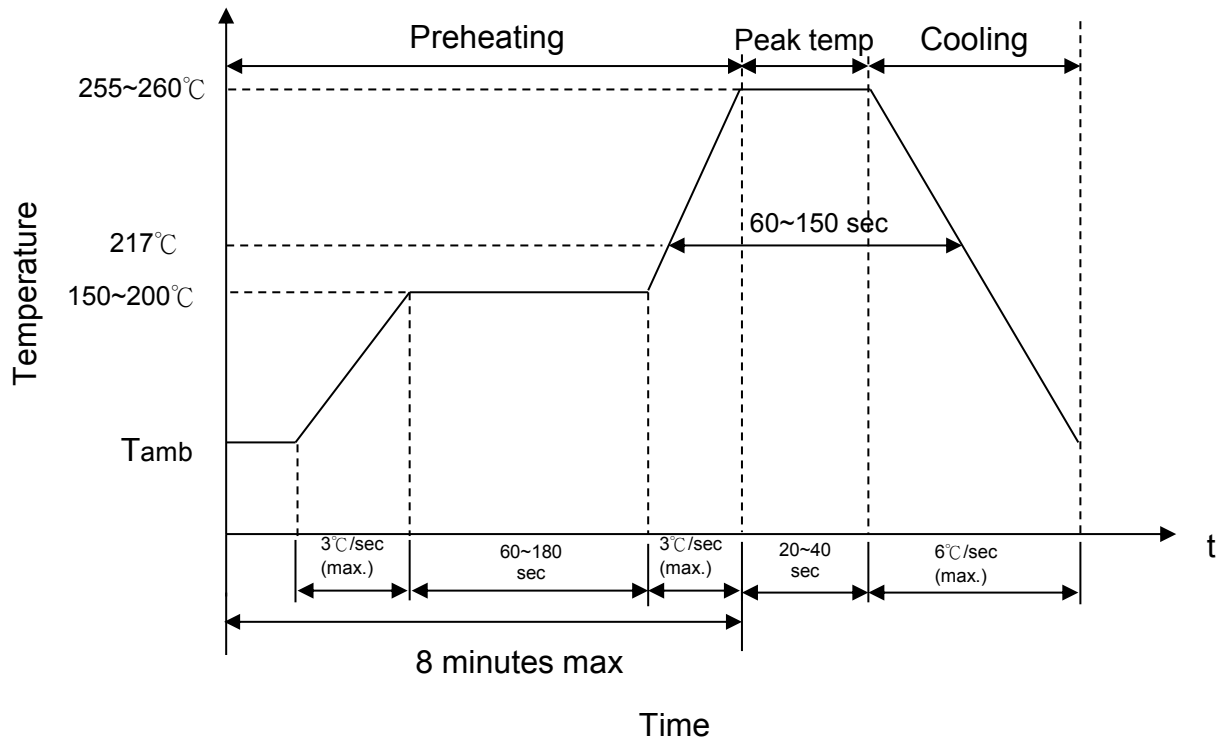

■ Recommended Reworking Conditions with Soldering Iron

Item	Conditions
Temperature of Soldering Iron-tip	360°C (max.)
Soldering Time	3 sec (max.)
Diameter of Soldering Iron-tip	φ 3mm (max.)
Caution: Not to touch the component surface with soldering iron directly to prevent component damage.	

Recommended Soldering Pad Dimensions

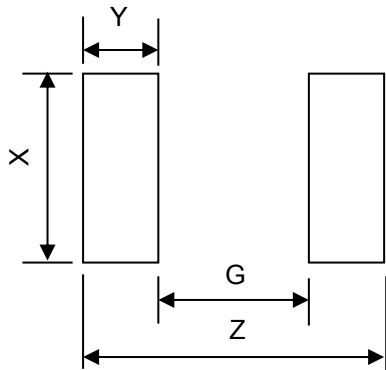

Size (EIA)	0603
Z	3.0 mm
G	1.0 mm
X	1.0 mm
Y	1.0 mm

RoHS Compliant Declaration

We hereby declare that the components delivered to your company are compliant with RoHS directive 2011/65/EU.

Warehouse Storage Conditions of Products

(I) Storage Conditions :

- 1.Storage Temperature : -10°C~+40°C
- 2.Relative Humidity : $\leq 75\%RH$
- 3.Keep away from corrosive atmosphere and sunlight.

(II) Period of Storage : 1 year

Packaging

■ Taping Specification (0603 Series)

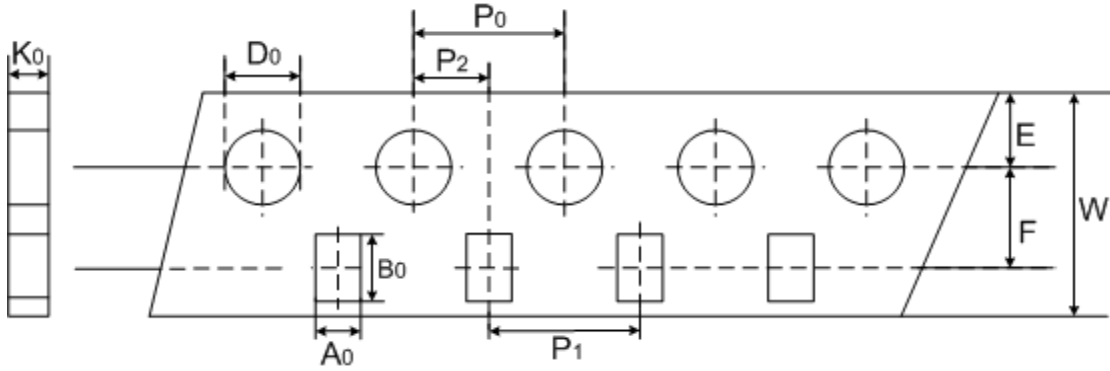

(Unit : mm)

Index	A_0	B_0	W	E	F	P_1	P_2	P_0	D_0	K_0
Size	± 0.2	± 0.2	± 0.2	± 0.1	± 0.05	± 0.1	± 0.05	± 0.1	± 0.1	± 0.1
0603	1.1	1.9	8.0	1.75	3.5	4.0	2.0	4.0	1.55	0.95

■ Quantity (4000 pcs / reel)

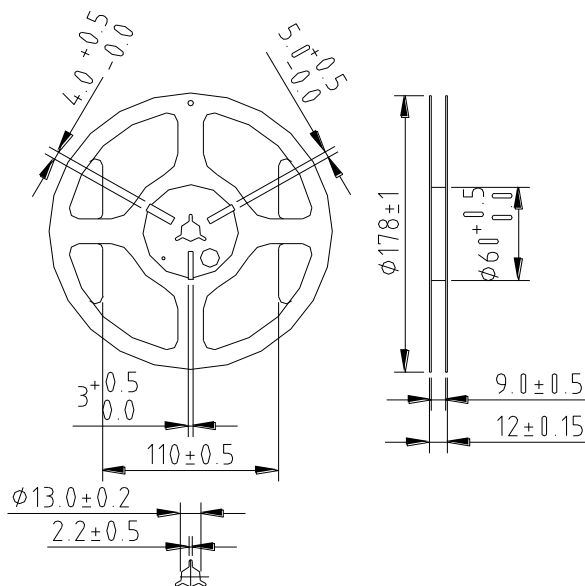

Safety Approvals (Certified Model/Type : TPM1S471P115)



* UL 1434 / cUL recognized (File # E138827)



* TUV recognized (File # R 50133294)

Certificates

- (1) TS 16949 certificate
- (2) ISO 9001 certificate
- (3) QC 080000 certificate

Test Report

- (1) RoHS test report
- (2) Halogen-free test report

R-T Characteristic Curve

TPM1S471P115RT

