



APPROVAL SHEETS

Customer : CODICO/ GMBH

Part No. : 316858

Rev. :

Sample No. : YT-37271

Date of submission : 2023/10/31

Product : PLC Transformer (T3.94/2.24/2.3 SMD)

Please note items listed below does not meet your printed specifications and requires your consent for deviation:

Item	Printed Specification	Proposed Specification

Remark :

This part comply with RoHS requirement.

Please evaluate the samples, sign this approval sheet, and return by FAX to ELYTONE

- Approved
- Disapproved
- Conditional Approved

Comment :

Engineer:

Kotting

Verified:

Johnsen

Approved by :

Winding Procedure				Winding Direction:				
Step	Winding	Material Reference	Start		Finish		No.of Turns	Remark
			Pin No.	Wire Between	Pin No.	Wire Between		
1	W1	WIRE:AWG#35 180°C MW83C HEAVY R	2		1		9 Ref	Bifilar
	W2	WIRE:AWG#35 180°C MW83C HEAVY N	3		4		9 Ref	

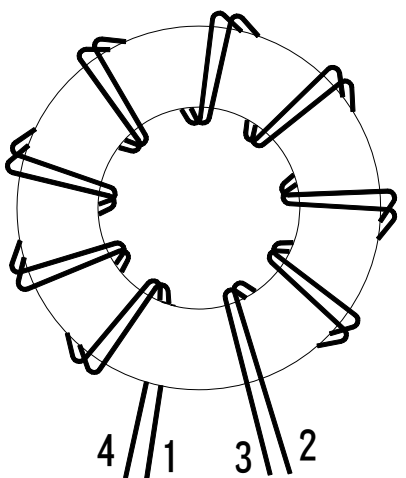
Cross section of winding's construction	Treatment and Assembly:								
	<p>Termination & Soldering : Lead free of solder.</p> <p>Core Assembly : Secure coil on case with epoxy.</p> <p>Marking : Mark the component with a black permanent ink at shown location.</p> <div style="text-align: center;"> <table border="1"> <tr> <td>1</td> <td>4</td> </tr> <tr> <td>●</td> <td>316858</td> </tr> <tr> <td>EyywwMOXX</td> <td></td> </tr> <tr> <td>2</td> <td>3</td> </tr> </table> </div> <p>Varnish : N/A</p>	1	4	●	316858	EyywwMOXX		2	3
1	4								
●	316858								
EyywwMOXX									
2	3								

Customer : CODICO/ GMBH	Part No. : 316858	Rev.:	Sample No. : YT-37271
-------------------------	-------------------	-------	-----------------------

Electrical Requirements :				Remark :										
Testing Item		Specification	Pin No.	Samples tested data										
				1	2	3	4	5	6	7	8	6	20	
©	INDUCTANCE @100KHz,0.1V	12uH MIN	2 - 1	16.67	16.06	16.74	16.17	16.29						
		12uH MIN	3 - 4	16.67	16.07	16.74	16.18	16.28						
	INDUCTANCE @2MHz,1V	12uH Ref	2 - 1									16.3	16.8	
		12uH Ref	3 - 4									16.4	16.9	
	Leakage Inductance @100KHz, 0.1V WK-3260B	100 nH MAX (SHORTED 3,4)	2 - 1	62.69	64.10	62.71	63.89	66.21						
	DC RESISTANCE: 502AC	100 mΩ MAX	2 - 1	74.56	73.98	75.50	74.68	75.60						
		100 mΩ MAX	3 - 4	76.14	76.77	76.03	77.36	77.77						
	Dielectric Strength	1000VAC, 1mA, 2Sec	2 - 3	OK	OK	OK	OK	OK						

Dimension Measurement : (UNIT: mm)				Remark :									
Equipment	Specification	Position		1	2	3	4	5	6	7	8	6	20
micrometer	9.5 MAX	A		8.99	9.02	8.92	8.98	8.97					
Mitutoyo CD-6"B	5.88 MAX	B		5.75	5.75	5.74	5.75	5.72					
	© 5.0 MAX	C		4.51	4.56	4.51	4.57	4.56					
	5.5±0.2	D		5.58	5.62	5.59	5.59	5.64					
	0.1MAX	E		OK	OK	OK	OK	OK					
	2.54±0.15	F		2.49	2.47	2.49	2.47	2.49					
	7.3±0.2	G		7.32	7.30	7.32	7.32	7.32					
	0.5x0.3	H		0.49	0.48	0.48	0.48	0.48					

Customer :	CODICO/ GMBH	Part No. :	316858	Rev.:		Sample No. :	YT-37271
------------	--------------	------------	--------	-------	--	--------------	----------

Electrical Specification :

1. Inductance : @100KHz , 0.1V
2~1 12uH MIN
3~4 12uH MIN
2. Inductance : @2MHz , 1V
2~1 12uH Ref
3~4 12uH Ref
3. Leakage Inductance : @100KHz , 0.1V
2~1 100nH MAX (Shorted 3,4)
4. DC Resistance
2~1 100 mΩ MAX
3~4 100 mΩ MAX
5. Dielectric Strength
1000Vac , 1mA , 2Sec
6. Rated current 700mA (-40°C ~ +125°C)

Customer : CODICO/ GMBH

Part No. : 316858

Rev.:

Sample No. : YT-37271

Taping and packing

Dimensions in mm

Blister tape

Reel

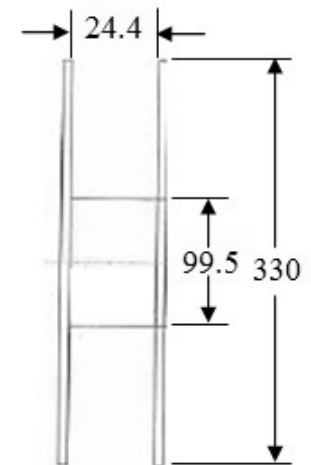
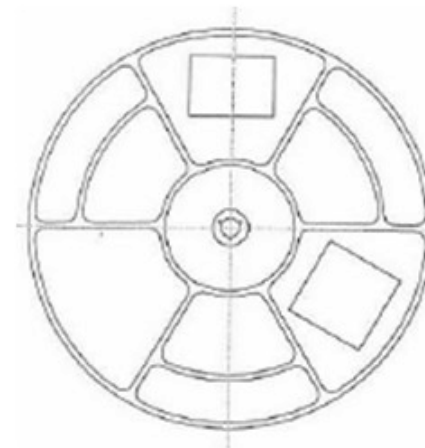
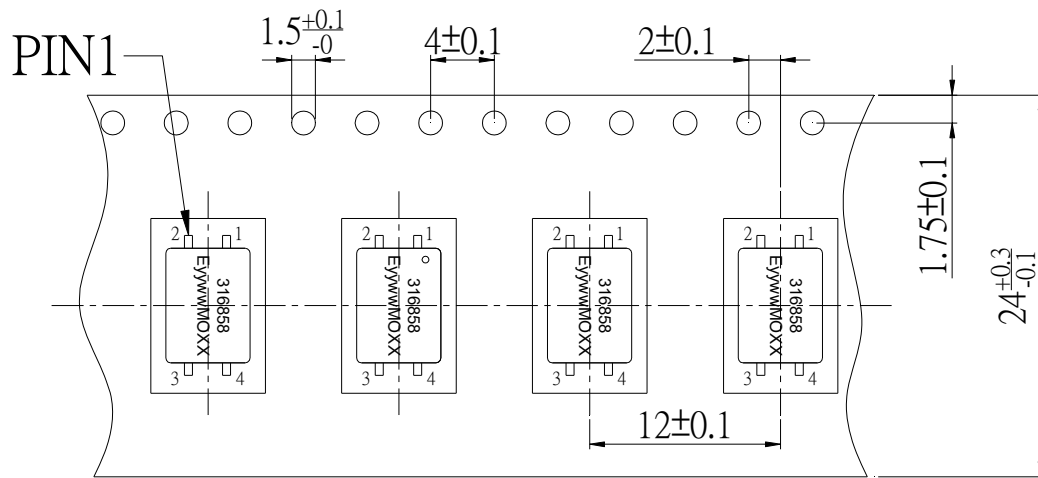

Direction of unreeling



Dimensions in mm

Qty: 1000PCS/REEL , 5000PCS/ Master carton

Customer : CODICO/ GMBH

Part No. : 316858

Rev.:

Sample No. : YT-37271