



正基科技股份有限公司

SPECIFICATION

PRODUCT NAME : AP12275_M2P

REVISION : 0.8

DATE : Aug 12th , 2020

Customer APPROVED	
Company	
Representative Signature	

PREPARED	REVIEW			APPROVED	DCC ISSUE
	PM	QA	ET		





正基科技股份有限公司



AP12275_M2P

Data Sheet

Address:

3F, No.15-1, Zhonghua Road, Hsinchu Industril Park, Hukou, Hsinchu,
Taiwan, 30352

Website: <http://www.ampak.com.tw/>



Revision

Revision	Date	Description	Revised By
0.1	2020/02/19	- Preliminary	Jason Shen
0.2	2020/03/09	- Modify RF Specification - Modify Pin-out	Jason Shen
0.3	2020/03/16	- Modify RF Specification	Jason Shen
0.4	2020/04/28	- Modify RF Specification	Jason Shen
0.5	2020/05/29	- Modify RF Specification	Jason Shen
0.6	2020/07/01	- Modify DC Characteristics	Jason Shen
0.7	2020/07/06	- Modify Pin outline	Jason Shen
0.8	2020/08/12	- Modify RF Specification	Jason Shen

Contents

1. Introduction	2
1.1 Overview	2
1.2 Product Features.....	3
2. General Specification	4
2.1 General Specification.....	4
2.2 DC Characteristics	4
2.2.1 Absolute Maximum Ratings.....	4
2.2.2 Recommended Operating Rating	5
3. Wi-Fi RF Specification	6
3.1 2.4GHz RF Specification	6
3.2 5GHz RF Specification	8
4. Bluetooth Specification	14
4.1 Bluetooth Specification.....	14
5. Pin Definition	15
5.1 Pin Outline	15
5.2 Pin Assignment	15
6. Dimensions	18
6.1 Module Dimensions	18
7. Host Interface Timing Diagram	19
7.1 Power-up Sequence Timing Diagram.....	19
7.2 PCIe Interface Description.....	21
8. Package Information	24
8.1 Tray box	24
8.2 Carton.....	25



1. Introduction

1.1 Overview

The AMPAK Technology® AP12275_M2P is a fully Wi-Fi and Bluetooth functionalities 2230 M.2 card (KEY E) with seamless roaming capabilities and advance security, also it could interact with different vendors' 802.11a/b/g/n/ac/ax 2x2 Access Points with MIMO standard and can accomplish up to speed of 1200Mbps with dual stream in 802.11ax to connect the wireless LAN. Furthermore AP12275_M2P included PCIe interface for Wi-Fi, UART/ PCM interface for Bluetooth

In addition, this compact module is a total solution for a combination of Wi-Fi + BT technologies. The module is specifically developed for tablet, OTT box and portable devices.

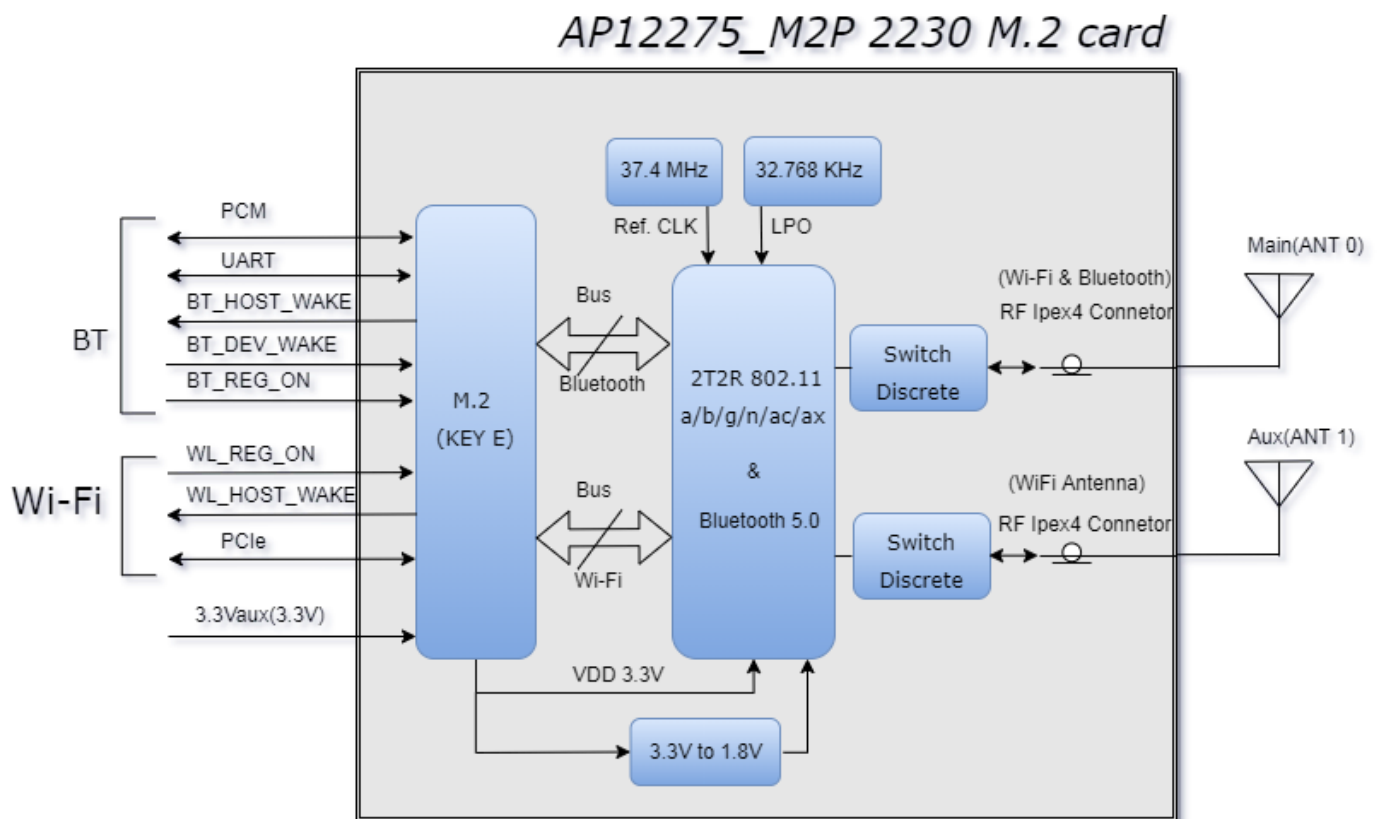

1.2 Product Features

IEEE 802.11 Key Feature

- Lead Free design which is compliant with ROHS requirements.
- TX and RX low-density parity check (LDPC) support for improved range and power efficiency.
- Dual-stream spatial multiplexing up to 1200 Mbps data rate.
- 20, 40, 80 MHz channels with optional SGI (1024 QAM modulation)
- IEEE 802.11ax beam forming.
- Client MU-MIMO.
- Supports 2 antennas with two for shared BT and WLAN port.
 - Supports PCI express revision 3.0 and power management running at Gen1 speeds.

Bluetooth Key Feature

- BT host digital interface:
 - HCI UART (up to 4 Mbps)
 - PCM for audio data
- Complies with Bluetooth Core Specification Version 5.0 with provisions for supporting future specifications. With Bluetooth Class 1 or Class2 transmitter operation.
- Supports extended synchronous connections (eSCO), for enhanced voice quality by allowing for retransmission of dropped packets.
- Adaptive frequency hopping (AFH) for reducing radio frequency interference.

A simplified block diagram of the module is depicted in the figure above.



2. General Specification

2.1 General Specification

Model Name	AP12275_M2P
Product Description	2T2R 802.11 a/b/g/n/ac/ax Wi-Fi + BT 5.0 2230 M.2 card (KEY E)
Dimension	L x W : 30 x 22 mm (typical); H : 2.4 mm (max.)
WiFi Interface	PCI express revision 3.0 at Gen1 speeds
BT Interface	UART / PCM
Operating temperature	-30°C to 85°C
Storage temperature	-40°C to 105°C
Humidity	Operating Humidity 10% to 95% Non-Condensing Storage Humidity 5% to 95% Non-Condensing

Note: The optimal RF performance specified in the data sheet, however, is guaranteed only -10 °C to +55 °C and 3.2V < 3.3Vaux < 3.6V without derating performance.

2.2 DC Characteristics

2.2.1 Absolute Maximum Ratings

Symbol	Description	Min.	Max.	Unit
3.3Vaux	Input supply voltage	-0.5	4.5	V
I/O Voltage	Digital I/O Voltage	-0.5	2.07	V
WL_REG_ON	Used by PMU to power up or power down the internal regulators used by the WLAN section.			
BT_REG_ON	Used by PMU to power up or power down the internal regulators used by the Bluetooth section.			
WL_HOST_WAKE	WLAN device wake-up HOST			
BT_HOST_WAKE	Bluetooth device wake-up HOST			
BT_DEV_WAKE	HOST wake-up Bluetooth device			
CLKREQ0#	PCIe clock request, active low.			
PEWAKE0#	PCIe PME Wake, active low.			
PCIE_PERST_L	PCIe host indication to reset the device.			



Extreme caution must be exercised to prevent electrostatic discharge (ESD) damage.

Symbol	Condition	ESD Rating	Unit
ESD_HAND_HBM	Human body model contact discharge per JEDEC EID/JESD22-A114	1.5	kV
ESD_HAND_CDM	Charged device model contact discharge per JEDEC EIA/JESD22-C101	250	V

2.2.2 Recommended Operating Rating

Voltage rails	Min.	Typ.	Max.	Unit
3.3Vaux	3.0	3.3	3.6	V
Digital I/O Voltage	1.68	1.8	1.98	V
WL_REG_ON				
BT_REG_ON				
WL_HOST_WAKE				
BT_HOST_WAKE				
BT_DEV_WAKE				
CLKREQ0#				
PEWAKE0#				
PCIE_PERST_L				

3.3Vaux current consumption 1200mA(Peak), when 3.3Vaux = 3.3V

The module requires two power supplies: Digital I/O Pins.

I/O Voltage	Min.	Max.	Unit
VIH	1.17	N/A	V
VIL	N/A	0.72	V
VOH output@2mA	1.4	N/A	V
VOL output@2mA	N/A	0.4	V

3. Wi-Fi RF Specification

3.1 2.4GHz RF Specification

Conditions : 3.3Vaux=3.3V ; Temp:25°C

Feature	Description				
WLAN Standard	IEEE 802.11b/g/n/ax & Wi-Fi compliant				
Frequency Range	2.400 GHz ~ 2.4835 GHz (2.4GHz ISM Band)				
Number of Channels	2.4GHz : Ch1 ~ Ch13				
Modulation	802.11b : DQPSK 、 DBPSK 、 CCK 802.11 g/n : OFDM /64-QAM 、 16-QAM 、 QPSK 、 BPSK 802.11ax : OFDM /256-QAM 、 64-QAM 、 16-QAM 、 QPSK 、 BPSK				
Output Power , tolerance ± 1.5 dB					
The transmit EVM quality & spectrum mask are compliant with IEEE 802.11 standard					
802.11b	1Mbps	2Mbps	5.5Mbps	11Mbps	
	18.5	18.5	18.5	18.5	
802.11g	6 、 9Mbps	12 、 18Mbps	24Mbps	36Mbps	48Mbps
	18	18	17.5	17.5	17
	54Mbps				
	17				
802.11n 20MHz	MCS0~2	MCS3	MCS4	MCS5	MCS6
	18	17.5	17.5	17	17
	MCS7				
	16				
802.11ax 20MHz	HE0~2	HE3	HE4	HE5	HE6
	18	17.5	17.5	17	17
	HE7	HE8	HE9		
	16	15	15		
Note: The specifications of RF output power are subject to change to fulfill the safety regulation and requirements in end-user product.					
Sensitivity, tolerance ± 2 dB					
CCK modulation PER $\leq 8\%$ 、 OFDM modulation PER $\leq 10\%$					
802.11b	Data Rate	Spec.(dBm)			
	1Mbps	-96			
	2Mbps	-92			
	5.5Mbps	-90			
	11Mbps	-88			



802.11g SISO	Data Rate	Spec.(dBm)	Data Rate	Spec.(dBm)
	6Mbps	-92	24Mbps	-84
	9Mbps	-91	36Mbps	-81
	12Mbps	-90	48Mbps	-77
	18Mbps	-87	54Mbps	-75
802.11g MIMO	Data Rate	Spec.(dBm)	Data Rate	Spec.(dBm)
	6Mbps	-94	24Mbps	-86
	9Mbps	-93	36Mbps	-83
	12Mbps	-92	48Mbps	-80
	18Mbps	-89	54Mbps	-77
802.11n_20MHz SISO	Data Rate	Spec.(dBm)	Data Rate	Spec.(dBm)
	MCS0	-91	MCS4	-80
	MCS1	-88	MCS5	-78
	MCS2	-86	MCS6	-75
	MCS3	-83	MCS7	-74
802.11n_20MHz MIMO	Data Rate	Spec.(dBm)	Data Rate	Spec.(dBm)
	MCS0	-92	MCS5	-79
	MCS1	-91	MCS6	-77
	MCS2	-89	MCS7	-75
	MCS3	-86	MCS8	-71
	MCS4	-82	MCS15	-72
802.11ax_20MHz SISO	Data Rate	Spec.(dBm)	Data Rate	Spec.(dBm)
	HE0	-92	HE6	-75
	HE1	-88	HE7	-75
	HE2	-86	HE8	-71
	HE3	-83	HE9	-69
	HE4	-80		
	HE5	-78		
Maximum Input Level	802.11b : -10 dBm			
	802.11g/n/ax : -20 dBm			



3.2 5GHz RF Specification

Conditions : 3.3Vaux=3.3V ; Temp:25°C

Feature	Description				
WLAN Standard	IEEE 802.11a/n/ac/ax & Wi-Fi compliant				
Frequency Range	5.15~5.35GHz 、 5.47~5.725GHz 、 5.725~5.85GHz (5GHz UNII Band)				
Number of Channels	5.15~5.35GHz : Ch36 ~ Ch64 5.47~5.725GHz : Ch100 ~ Ch140 5.725~5.85GHz : Ch149 ~ Ch165				
Modulation	802.11a : OFDM /64-QAM 、 16-QAM 、 QPSK 、 BPSK 802.11n : OFDM /64-QAM 、 16-QAM 、 QPSK 、 BPSK 802.11ac : OFDM /256-QAM 、 OFDM /64-QAM 、 16-QAM 、 QPSK 、 BPSK 802.11ax : OFDM/ 1024-QAM 、 OFDM /256-QAM 、 OFDM /64-QAM 、 16-QAM 、 QPSK 、 BPSK				
Output Power , tolerance ± 2 dB					
The transmit EVM quality & spectrum mask are compliant with IEEE 802.11 standard					
802.11a	Frequency (MHz)	6~9Mbps	12~18Mbps	24Mbps	36Mbps
	5150~5350	15.5	15.5	15	15
	5470~5720	15.5	15.5	15	15
	5725~5845	15.5	15.5	15	15
	Frequency (MHz)	48Mbps	54Mbps		
	5150~5350	14.5	14.5		
	5470~5720	14.5	14.5		
	5725~5845	14.5	14.5		
802.11n 20MHz	Frequency (MHz)	MCS0~2	MCS3	MCS4	MCS5
	5150~5350	15	15	14.5	14.5
	5470~5720	15	15	14.5	14.5
	5725~5845	15	15	14.5	14.5
	Frequency (MHz)	MCS6	MCS7		
	5150~5350	13.5	13.5		
	5470~5720	13.5	13.5		
	5725~5845	13.5	13.5		



802.11n 40MHz	Frequency (MHz)	MCS0~2	MCS3	MCS4	MCS5
	5150~5350	15	15	14	14
	5470~5720	15	15	14	14
	5725~5845	15	15	14	14
	Frequency (MHz)	MCS6	MCS7		
	5150~5350	13.5	13.5		
	5470~5720	13.5	13.5		
5725~5845	13.5	13.5			
802.11ac 20MHz	Frequency (MHz)	MCS0~2	MCS3	MCS4	MCS5
	5150~5350	15	15	14.5	14.5
	5470~5720	15	15	14.5	14.5
	5725~5845	15	15	14.5	14.5
	Frequency (MHz)	MCS6	MCS7	MCS8	
	5150~5350	13.5	13.5	11	
	5470~5720	13.5	13.5	11	
5725~5845	13.5	13.5	11		
802.11ac 40MHz	Frequency (MHz)	MCS0~2	MCS3	MCS4	MCS5
	5150~5350	15	14	14	14
	5470~5720	15	14	14	14
	5725~5845	15	14	14	14
	Frequency (MHz)	MCS6	MCS7	MCS8	MCS9
	5150~5350	13.5	13.5	11	9
	5470~5720	13.5	13.5	11	9
5725~5845	13.5	13.5	11	9	
802.11ac 80MHz	Frequency (MHz)	MCS0~2	MCS3	MCS4	MCS5
	5150~5350	15	14	13.5	13.5
	5470~5720	15	14	13.5	13.5
	5725~5845	15	14	13.5	13.5
	Frequency (MHz)	MCS6	MCS7	MCS8	MCS9
	5150~5350	13	13	9	9
	5470~5720	13	13	9	9
5725~5845	13	13	9	9	

802.11ax 20MHz	Frequency (MHz)	HE0~2	HE3	HE4	HE5
	5150~5350	15	14.5	14.5	14.5
	5470~5720	15	14.5	14.5	14.5
	5725~5845	15	14.5	14.5	14.5
	Frequency (MHz)	HE6	HE7	HE8	HE9
	5150~5350	13.5	13.5	11	11
	5470~5720	13.5	13.5	11	11
	5725~5845	13.5	13.5	11	11
	Frequency (MHz)	HE10	HE11		
	5150~5350	9	9		
	5470~5720	9	9		
	5725~5845	9	9		
	802.11ax 40MHz	Frequency (MHz)	HE0~2	HE3	HE4
5150~5350		15	14	14	14
5470~5720		15	14	14	14
5725~5845		15	14	14	14
Frequency (MHz)		HE6	HE7	HE8	HE9
5150~5350		13.5	13.5	11	9
5470~5720		13.5	13.5	11	9
5725~5845		13.5	13.5	11	9
Frequency (MHz)		HE10	HE11		
5150~5350		7	7		
5470~5720		7	7		
5725~5845		7	7		
802.11ax 80MHz		Frequency (MHz)	HE0~2	HE3	HE4
	5150~5350	15	14	13.5	13.5
	5470~5720	15	14	13.5	13.5
	5725~5845	15	14	13.5	13.5
	Frequency (MHz)	HE6	HE7	HE8	HE9
	5150~5350	13	13	9	9
	5470~5720	13	13	9	9
	5725~5845	13	13	9	9
	Frequency (MHz)	HE10	HE11		
	5150~5350	7	7		
	5470~5720	7	7		
	5725~5845	7	7		

Note: The specifications of RF output power are subject to change to fulfill the safety regulation and requirements in end-user product.

Sensitivity, tolerance ± 2 dB
OFDM modulation PER $\leq 10\%$

	Data Rate	Spec.(dBm)	Data Rate	Spec.(dBm)
802.11a SISO	6Mbps	-89	24Mbps	-82
	9Mbps	-88	36Mbps	-79
	12Mbps	-87	48Mbps	-74
	18Mbps	-85	54Mbps	-72
MIMO802.11a MIMO	6Mbps	-91	24Mbps	-85
	9Mbps	-90	36Mbps	-82
	12Mbps	-89	48Mbps	-77
	18Mbps	-88	54Mbps	-76
802.11n_20MHz SISO	MCS0	-89	MCS4	-78
	MCS1	-87	MCS5	-75
	MCS2	-85	MCS6	-72
	MCS3	-82	MCS7	-70
802.11n_20MHz MIMO	MCS0	-91	MCS5	-77
	MCS1	-90	MCS6	-75
	MCS2	-88	MCS7	-73
	MCS3	-85	MCS8	-88
	MCS4	-81	MCS15	-69
802.11n_40MHz SISO	MCS0	-87	MCS4	-76
	MCS1	-85	MCS5	-71
	MCS2	-82	MCS6	-69
	MCS3	-79	MCS7	-67
802.11n_40MHz MIMO	MCS0	-87	MCS5	-74
	MCS1	-87	MCS6	-72
	MCS2	-85	MCS7	-70
	MCS3	-82	MCS8	-85
	MCS4	-78	MCS15	-66



802.11ac_20MHz SISO	Data Rate	Spec.(dBm)	Data Rate	Spec.(dBm)
	MCS0	-89	MCS5	-74
	MCS1	-87	MCS6	-72
	MCS2	-85	MCS7	-69
	MCS3	-82	MCS8	-67
	MCS4	-78		
802.11ac_20MHz MIMO	Data Rate	Spec.(dBm)	Data Rate	Spec.(dBm)
	MCS0,NSS=1	-91	MCS6,NSS=1	-75
	MCS1,NSS=1	-90	MCS7,NSS=1	-74
	MCS2,NSS=1	-87	MCS8,NSS=1	-71
	MCS3,NSS=1	-84	MCS0,NSS=2	-87
	MCS4,NSS=1	-81	MCS8,NSS=2	-64
	MCS5,NSS=1	-76		
802.11ac_40MHz SISO	Data Rate	Spec.(dBm)	Data Rate	Spec.(dBm)
	MCS0	-87	MCS5	-71
	MCS1	-85	MCS6	-69
	MCS2	-82	MCS7	-68
	MCS3	-79	MCS8	-64
	MCS4	-75	MCS9	-63
802.11ac_40MHz MIMO	Data Rate	Spec.(dBm)	Data Rate	Spec.(dBm)
	MCS0,NSS=1	-89	MCS6,NSS=1	-72
	MCS1,NSS=1	-87	MCS7,NSS=1	-71
	MCS2,NSS=1	-85	MCS8,NSS=1	-67
	MCS3,NSS=1	-81	MCS9,NSS=1	-65
	MCS4,NSS=1	-78	MCS0,NSS=2	-85
	MCS5,NSS=1	-76	MCS9,NSS=2	-59
802.11ac_80MHz SISO	Data Rate	Spec.(dBm)	Data Rate	Spec.(dBm)
	MCS0	-84	MCS5	-67
	MCS1	-81	MCS6	-66
	MCS2	-78	MCS7	-64
	MCS3	-75	MCS8	-61
	MCS4	-72	MCS9	-60



802.11ac_80MHz MIMO	Data Rate	Spec.(dBm)	Data Rate	Spec.(dBm)
	MCS0,NSS=1	-86	MCS6,NSS=1	-69
	MCS1,NSS=1	-84	MCS7,NSS=1	-67
	MCS2,NSS=1	-81	MCS8,NSS=1	-65
	MCS3,NSS=1	-78	MCS9,NSS=1	-62
	MCS4,NSS=1	-75	MCS0,NSS=2	-82
	MCS5,NSS=1	-70	MCS9,NSS=2	-57
802.11ax_20MHz SISO	Data Rate	Spec.(dBm)	Data Rate	Spec.(dBm)
	HE0	-89	HE6	-72
	HE1	-87	HE7	-69
	HE2	-85	HE8	-67
	HE3	-82	HE9	-63
	HE4	-78	HE10	-58
	HE5	-74	HE11	-56
802.11ax_40MHz SISO	Data Rate	Spec.(dBm)	Data Rate	Spec.(dBm)
	HE0	-87	HE6	-69
	HE1	-85	HE7	-68
	HE2	-82	HE8	-64
	HE3	-79	HE9	-63
	HE4	-75	HE10	-59
	HE5	71	HE11	-54
802.11ax_80MHz SISO	Data Rate	Spec.(dBm)	Data Rate	Spec.(dBm)
	HE0	-84	HE6	-66
	HE1	-81	HE7	-64
	HE2	-78	HE8	-61
	HE3	-75	HE9	-60
	HE4	-72	HE10	-54
	HE5	-67	HE11	-50
Maximum Input Level	802.11a/n/ac/ax : -30 dBm			

4. Bluetooth Specification

4.1 Bluetooth Specification

Conditions : 3.3Vaux=3.3V ; Temp:25°C

Feature	Description
General Specification	
Bluetooth Standard	BDR(1Mbps) 、EDR(2 、3Mbps) 、LE(1Mbps) 、2LE(2Mbps)
Host Interface	UART
Frequency Band	2402 MHz ~ 2480 MHz
Number of Channels	79 channels for classic 、40 channels for BLE
Modulation	FHSS with GFSK, $\pi/4$ -DQPSK, 8DPSK
RF Specification	
Output Power , tolerance ± 1.5 dB	
	CL1 (dBm)
BDR Output Power	8
EDR Output Power	6
BLE Output Power	7
Sensitivity, tolerance ± 1.5 dB	
Sensitivity @ BER=0.1% for GFSK (1Mbps)	-88 dBm
Sensitivity @ BER=0.01% for $\pi/4$ -DQPSK (2Mbps)	-91 dBm
Sensitivity @ BER=0.01% for 8DPSK (3Mbps)	-85 dBm
Sensitivity @ BER=0.01% for LE (1Mbps)	-91 dBm
Sensitivity @ BER=0.01% for 2LE (2Mbps)	-90 dBm
Maximum Input Level	GFSK (1Mbps):-20dBm
	$\pi/4$ -DQPSK (2Mbps) :-20dBm
	8DPSK (3Mbps) :-20dBm

Note* : The Bluetooth BDR output power is able to be configured by firmware (hcd file).

AMPAK Technology Inc.



5. Pin Definition

5.1 Pin Outline

M.2_2			
1		2	
3	GND	3.3Vaux	4
5	NC	3.3Vaux	6
7	NC	NC	8
9	GND	PCM_CLK	10
11	NC	PCM_SYNC	12
13	NC	PCM_OUT	14
15	NC	PCM_IN	16
17	NC	NC	18
19	NC	GND	20
21	NC	BT_HOST_WAKE	22
23	WL_HOST_WAKE	UART_TXD	24
25	WL_REG_ON	Key	26
27	Key	Key	28
29	Key	Key	30
31	Key	Key	32
33	Key	UART_RXD	34
35	GND	UART_RTS_N	36
37	PERp0	UART_CTS_N	38
39	PERn0	NC	40
41	GND	NC	42
43	PETp0	BT_REG_ON	44
45	PETn0	NC	46
47	GND	NC	48
49	REFCLKP0	NC	50
51	REFCLKN0	EXT_LPO	52
53	GND	PERST0#	54
55	CLKREQ0#	BT_DEV_WAKE	56
57	PEWake0#	NC	58
59	GND	NC	60
61	NC	NC	62
63	NC	NC	64
65	GND	NC	66
67	NC	NC	68
69	NC	NC	70
71	GND	NC	72
73	NC	3.3Vaux	74
75	NC	3.3Vaux	
	GND		

5.2 Pin Assignment

NO	Name	Type	Description
TOP			
1	GND	G	Ground connections
3	NC	—	No connect
5	NC	—	No connect
7	GND	G	Ground connections
9	NC	—	No connect
11	NC	—	No connect
13	NC	—	No connect
15	NC	—	No connect
17	NC	—	No connect
19	NC	—	No connect
21	WL_HOST_WAKE	O	WLAN wake up HOST



23	WL_REG_ON	I	Used by PMU to power up or power down the internal module regulators used by the WLAN section.
	Module Key	—	Mechanical Key
	Module Key	—	Mechanical Key
	Module Key	—	Mechanical Key
	Module Key	—	Mechanical Key
33	GND	G	Ground connections
35	PERp0	I	PCI Express receive data-Positive
37	PERn0	I	PCI Express receive data-Negative
39	GND	G	Ground connections
41	PETp0	O	PCI Express transmit data-Positive
43	PETn0	O	PCI Express transmit data-Negative
45	GND	G	Ground connections
47	REFCLKP0	I	PCI Express differential clock input-Positive
49	REFCLKN0	I	PCI Express differential clock input-Negative
51	GND	G	Ground connections
53	CLKREQ0#	I/O	PCIe clock request
55	PEWAKE0#	OD	PCIe PME Wake
57	GND	G	Ground connections
59	NC	—	No connect
61	NC	—	No connect
63	GND	G	Ground connections
65	NC	—	No connect
67	NC	—	No connect
69	GND	G	Ground connections
71	NC	—	No connect
73	NC	—	No connect
75	GND	G	Ground connections
BOTTOM			
2	3.3Vaux	P	VDD system power supply input
4	3.3Vaux	P	VDD system power supply input
6	NC	—	No connect
8	PCM_CLK	I/O	PCM clock
10	PCM_SYNC	I/O	PCM sync signal
12	PCM_OUT	O	PCM Data output
14	PCM_IN	I	PCM data input
16	NC	—	No connect



18	GND	G	Ground connections
20	BT_HOST_WAKE	O	Bluetooth wake up Host
22	UART_TXD	O	Bluetooth UART interface
	Module Key	—	Mechanical Key
	Module Key	—	Mechanical Key
	Module Key	—	Mechanical Key
	Module Key	—	Mechanical Key
32	UART_RXD	I	Bluetooth UART interface
34	UART_RTS_N	O	Bluetooth UART interface
36	UART_CTS_N	I	Bluetooth UART interface
38	NC	—	No connect
40	NC	—	No connect
42	BT_REG_ON	I	Used by PMU to power up or power down the internal module regulators used by the Bluetooth section.
44	NC	—	No connect
46	NC	—	No connect
48	NC	—	No connect
50	NC	—	No connect
52	PERST0#	I	PCIe host indication to reset the device
54	BT_DEV_WAKE	I	HOST wake-up Bluetooth device
56	NC	—	No connect
58	NC	—	No connect
60	NC	—	No connect
62	NC	—	No connect
64	NC	—	No connect
66	NC	—	No connect
68	NC	—	No connect
70	NC	—	No connect
72	3.3Vaux	P	VDD system power supply input
74	3.3Vaux	P	VDD system power supply input

6. Dimensions

6.1 Module Dimensions

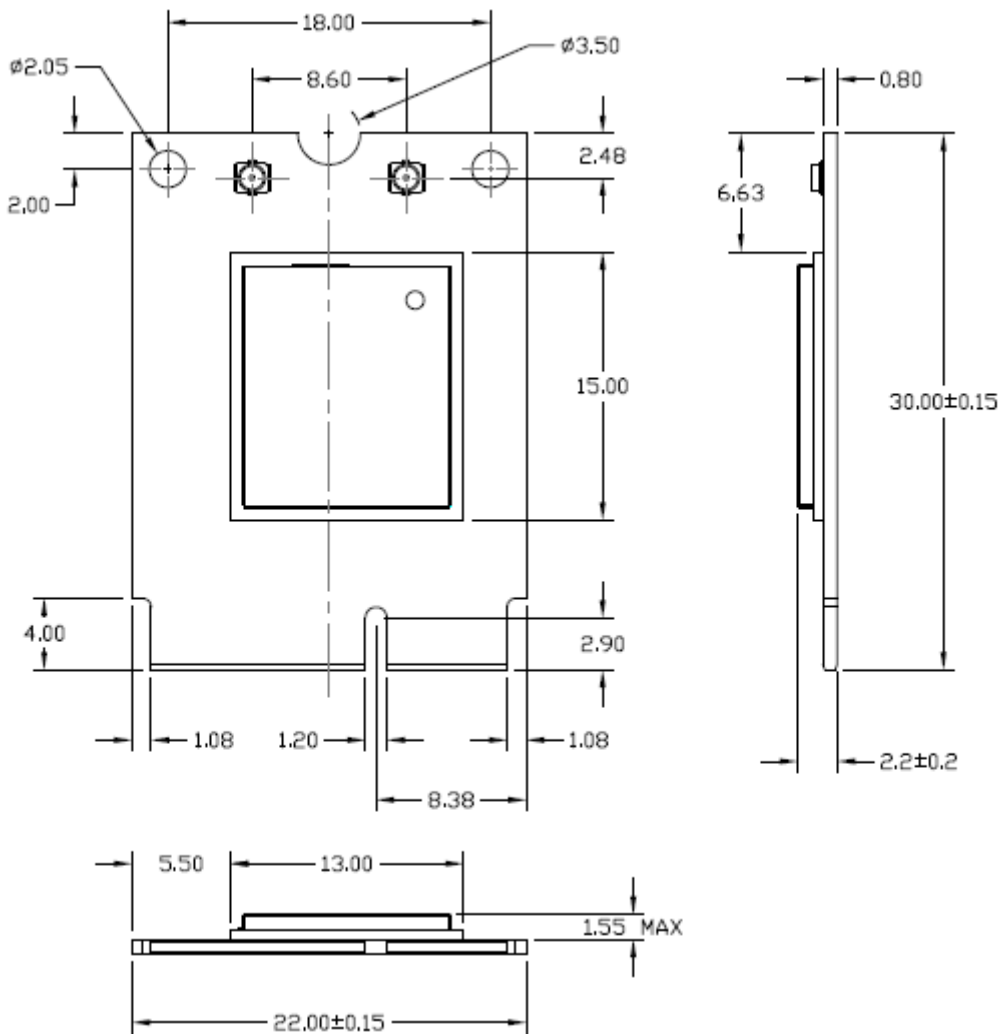
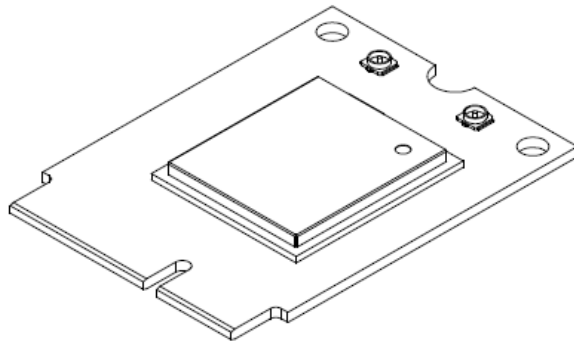

7. Host Interface Timing Diagram

7.1 Power-up Sequence Timing Diagram

The module has signals that allow the host to control power consumption by enabling or disabling the Bluetooth, WLAN and internal regulator blocks. These signals are described below.

Additionally, diagrams are provided to indicate proper sequencing of the signals for various operating states. The timing value indicated are minimum required values: longer delays are also acceptable.

- **WL_REG_ON:** Used by the PMU to power up or power down the internal regulators used by the WLAN section. When this pin is high, the regulators are enabled and the WLAN section is out of reset. When this pin is low the WLAN section is in reset.
- **BT_REG_ON:** Used by the PMU to power up or power down the internal regulators used by the BT section. Low asserting reset for Bluetooth. This pin has no effect on WLAN and does not control any PMU functions. This pin must be driven high or low (not left floating).

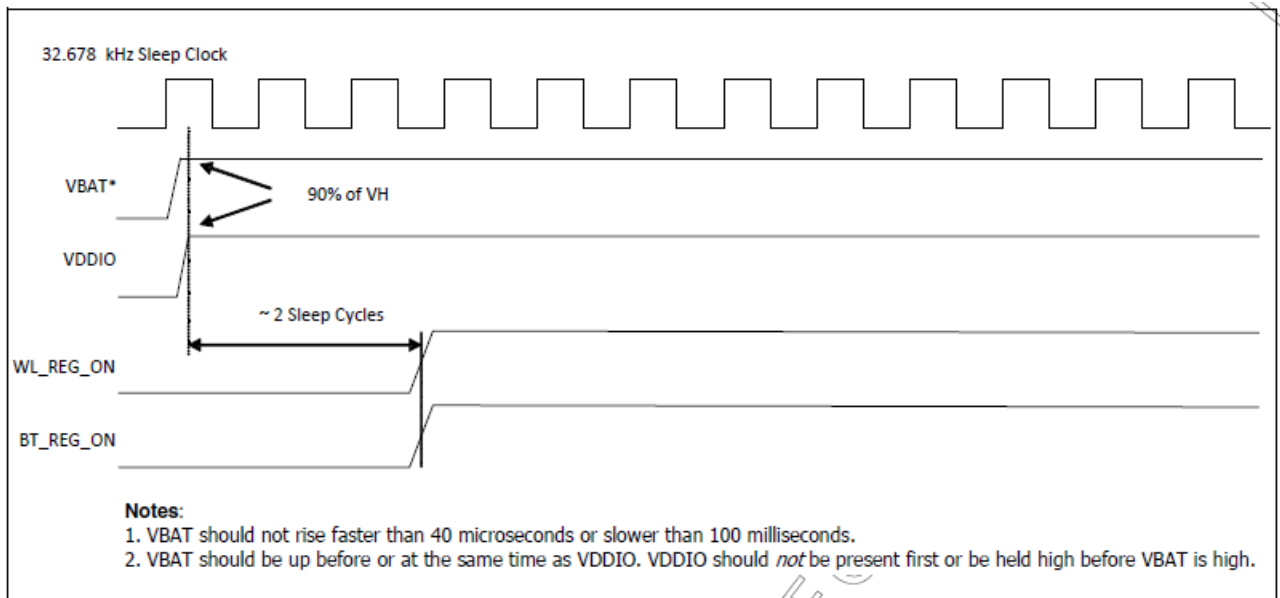

WLAN=ON, Bluetooth=ON

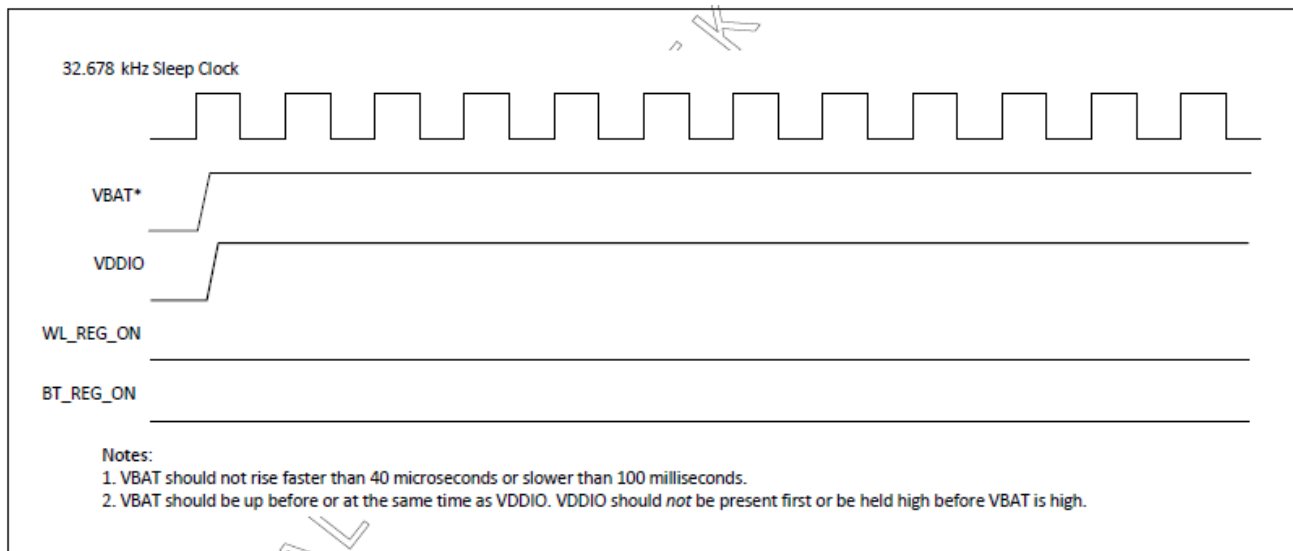

WLAN=OFF, Bluetooth=OFF



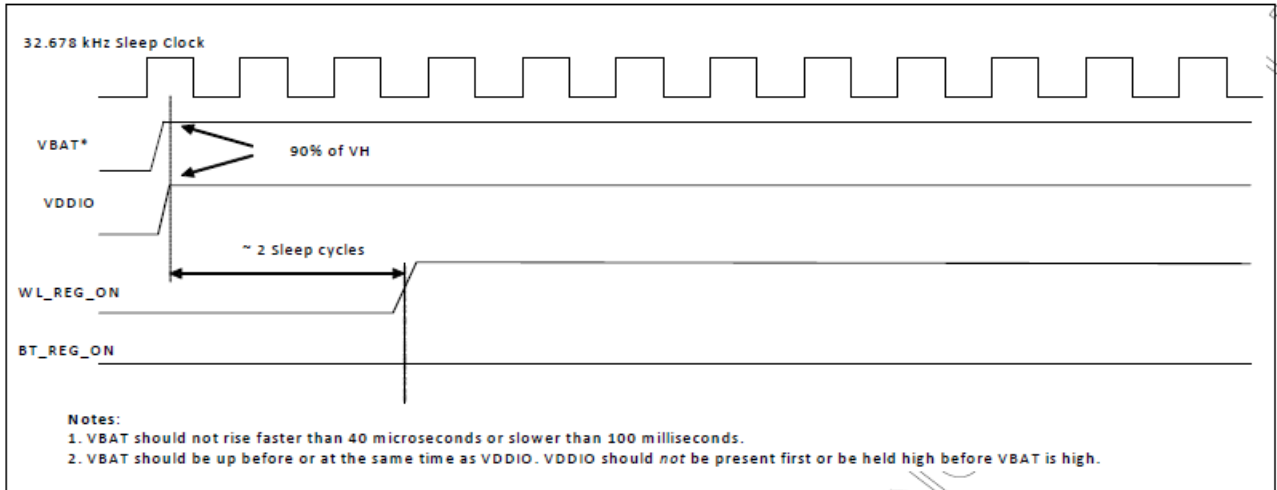

WLAN=ON, Bluetooth=OFF

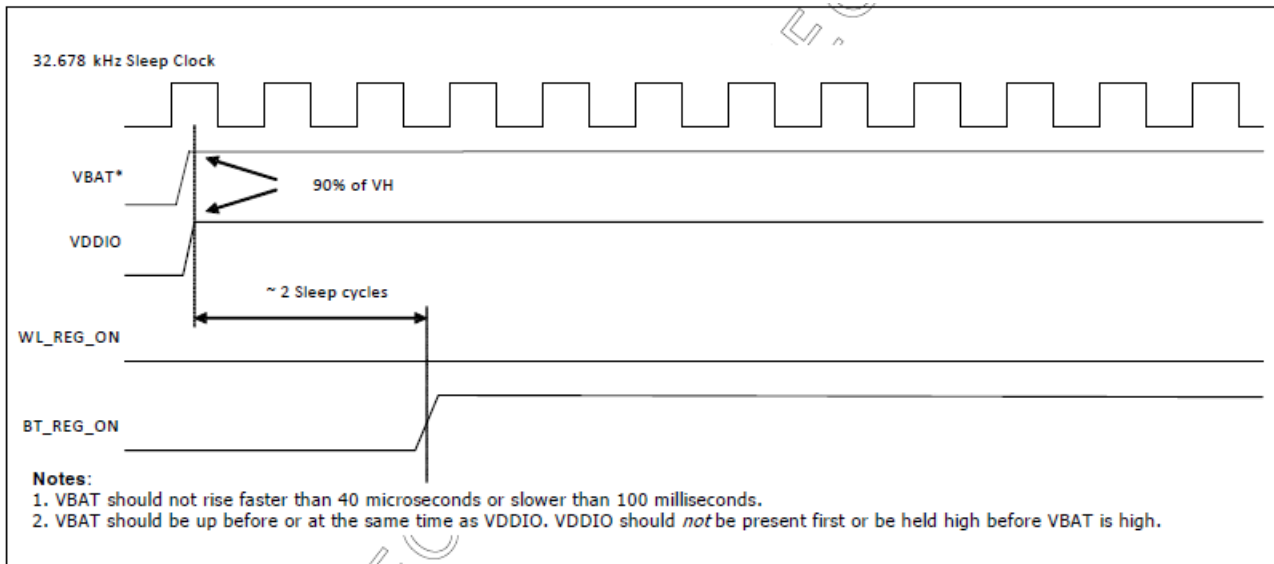

WLAN=OFF, Bluetooth=ON



7.2 PCIe Interface Description

The PCI Express (PCIe) core on the AP6275P is a high-performance serial I/O interconnect that is protocol compliant and electrically compatible with the PCI Express Base Specification v3.0 running at Gen2 speeds.

PCI Express Interface Parameters

Parameter	Symbol	Comments	Min.	Typ.	Max.	Unit
General^a						
Baud rate	BPS	—	—	5	—	Gbaud
Reference clock peak-to-peak differential ^b	Vref	LVPECL, AC coupled	0.95	—	—	V
Receiver						
Differential termination	ZRX-DIFF-DC	Differential termination	80	100	120	Ω
DC impedance	ZRX-DC	DC common-mode impedance	40	50	60	Ω
Powered down termination (POS)	ZRX-HIGH-IMP-DC-POS	Power-down or RESET high impedance	100k	—	—	Ω
Powered down termination (NEG)	ZRX-HIGH-IMP-DC-NEG	Power-down or RESET high impedance	1k	—	—	Ω
Input voltage	VRX-DIFFp-p	AC coupled, differential p-p	175	—	—	mV
Jitter tolerance	TRX-EYE	Minimum receiver eye width	0.4	—	—	UI
Differential return loss	RLRX-DIFF	Differential return loss	10	—	—	dB
Common-mode return loss	RLRX-CM	Common-mode return loss	6	—	—	dB
Unexpected electrical idle enter detect threshold integration time	TRX-IDEL-DET-DIFF-ENTERTIME	An unexpected electrical idle must be recognized no longer than this time to signal an unexpected idle condition.	—	—	10	ms
Signal detect threshold	VRX-IDLE-DET-DIFFp-p	Electrical idle detect threshold	65	—	175	mV
Transmitter						
Output voltage	VTX-DIFFp-p	Differential p-p, programmable in 16 steps	0.8	—	1200	mV
Output voltage rise time	VTX-RISE	20% to 80%	0.125 (2.5 GT/s) 0.15 (5 GT/s)	—	—	UI
Output voltage fall time	VTX-FALL	80% to 20%	0.125 (2.5 GT/s) 0.15 (5 GT/s)	—	—	UI
RX detection voltage swing	VTX-RCV-DETECT	The amount of voltage change allowed during receiver detection.	—	—	600	mV



PCI Express Interface Parameters (Continued)

Parameter	Symbol	Comments	Min.	Typ.	Max.	Unit
TX AC peak common-mode voltage (5 GT/s)	VTX-CM-AC-PP	TX AC common mode voltage (5 GT/s)	—	—	100	mV
TX AC peak common-mode voltage (2.5 GT/s)	VTX-CM-AC-P	TX AC common mode voltage (2.5 GT/s)	—	—	20	mV
Absolute delta of DC common-mode voltage during L0 and electrical idle	VTX-CM-DC-ACTIVE-IDLE-DELTA	Absolute delta of DC common-mode voltage during L0 and electrical idle.	0	—	100	mV
Absolute delta of DC common-mode voltage between D+ and D-	VTX-CM-DC-LINE-DELTA	DC offset between D+ and D-	0	—	25	mV
Electrical idle differential peak output voltage	VTX-IDLE-DIFF-AC-p	Peak-to-peak voltage	0	—	20	mV
TX short circuit current	ITX-SHORT	Current limit when TX output is shorted to ground.	—	—	90	mA
DC differential TX termination	ZTX-DIFF-DC	Low impedance defined during signaling (parameter is captured for 5.0 GHz by RLTX-DIFF)	80	—	120	Ω
Differential return loss	RLTX-DIFF	Differential return loss	10 (min) for 0.05: 1.25 GHz	—	—	dB
Common-mode return loss	RLTX-CM	Common-mode return loss	6	—	—	dB
TX eye width	TTX-EYE	Minimum TX eye width	0.75	—	—	UI



PCIe Power-On Timing

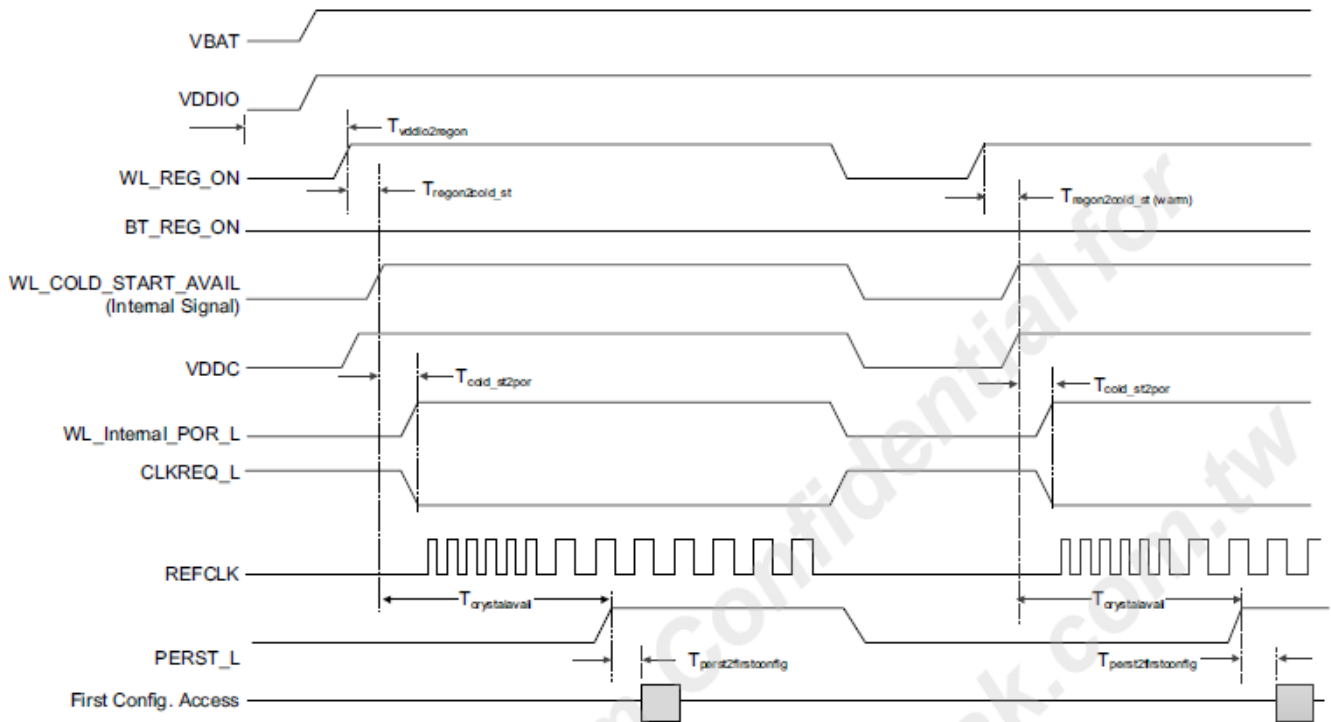

Timing Parameter	Notes	Value ^a	Unit
$T_{vddio2regon}$	–	0.1	ms
$T_{regon2cold_st}$	3.4 ms + 162 instruction-level parallelism (ILP) cycles	10.13	ms
T_{cold_st2por}	54 ILP cycles	2.24	ms
$T_{crystalavail}$	509 ILP cycles	21.17	ms
$T_{perst2firstconfig}$	–	6.0	ms
$T_{vddioon2firstconfig}$	$T_{vddio2regon} + T_{regon2cold_st} + T_{crystalavail} + T_{perst2firstconfig}$	37.4 ^b	ms
$T_{regon2cold_st (warm)}$	162 ILP cycles	6.73	ms

a. The time values assume an ILP tolerance of $\pm 30\%$.

b. With VDDIO as a reference, 37.4 ms is the minimum system wait time before issuing the first configuration access.



8. Package Information

8.1 Tray box

BOX : 100 PCS (100 PCS/Tray)

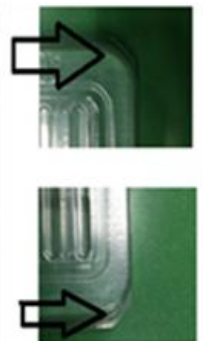
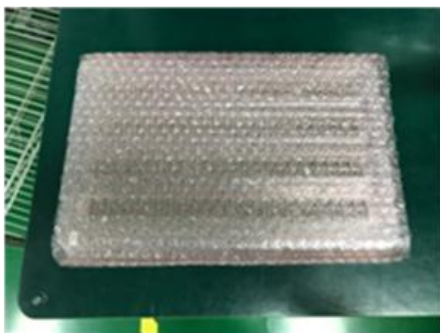

8.2 Carton

Carton: 400 PCS (Box*4/Carton)

