

Antenna

YE0001BA Datasheet

OC: YE0001BA



Version	Date	Author	Note
1.0	2020-08-27	Kenny YIN	Initial

Contents

Contents	1
1 Product Description.....	2
2 Product Features	2
3 Product Specifications	3
4 Overall Performance.....	4
5 Product Size	15

1 Product Description

The antenna is designed for superior performance, and can be widely used for wireless applications.

We provide comprehensive antenna design support such as simulation, testing and manufacturing for custom antenna solutions to meet your specific application needs.

2 Product Features

- Cellular LTE 4G & 5G
- High efficiency
- Excellent performance



3 Product Specifications

Passive Electrical Specifications

Frequency Range	600~6000 MHz
Input Impedence	50 Ω
VSWR	≤ 3.0
Gain	≤ 5 dBi
Polarization Type	Linear

Mechanical Specifications

Antenna Size	221 mm x 26.95 mm x 13.5 mm
Casing	ABS
Radiator	Cuprum
Connect Type	SMA (Male pin with internal thread)
Working Temperature	-20 °C to +80 °C
Radome Color	Black

4 Overall Performance

- Test Environment
 - KEYSIGHT VNA Network Analyzer E5063A 100 kHz – 6.5 GHz.
 - RayZone® 2800 Chamber 5G (FR1) SISO/MIMO, 400 MHz – 6.0 GHz.



● VSWR

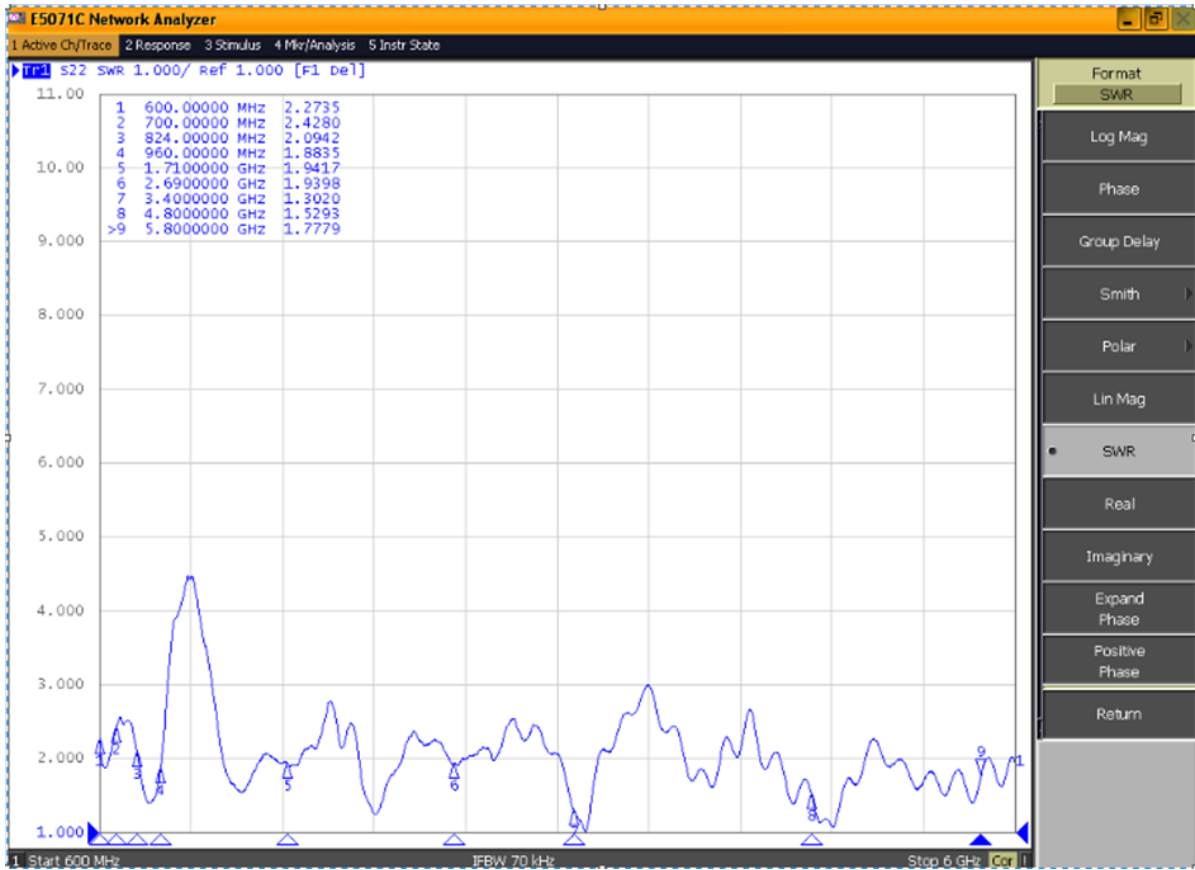

Frequency (MHz)	600	700	824	960	1710	2690	3400	4800	5800
VSWR	2.27	2.42	2.09	1.88	1.94	1.94	1.30	1.53	1.78

● Efficiency

600.00MHZ-2000.000MHZ Efficiency

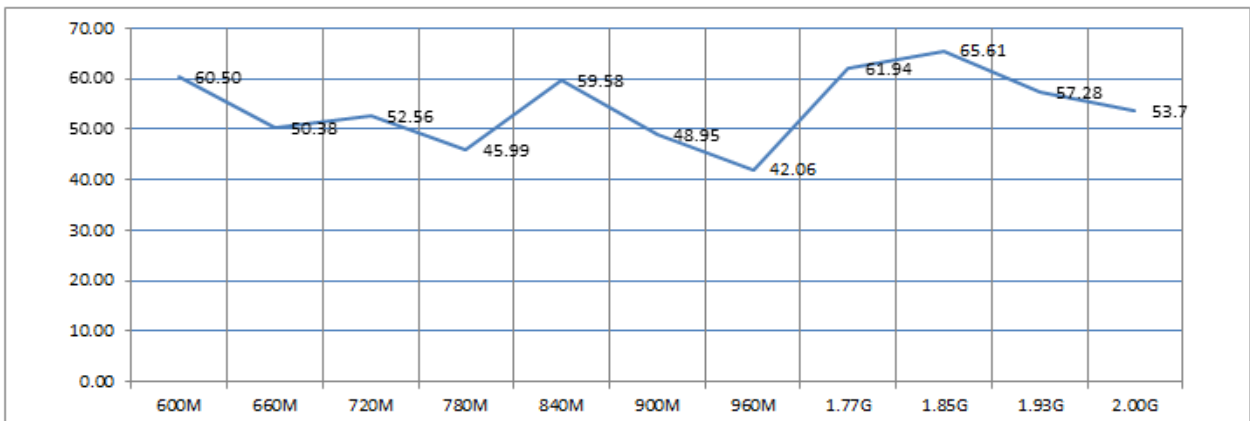

2000.00MHZ-4000.000MHZ Efficiency

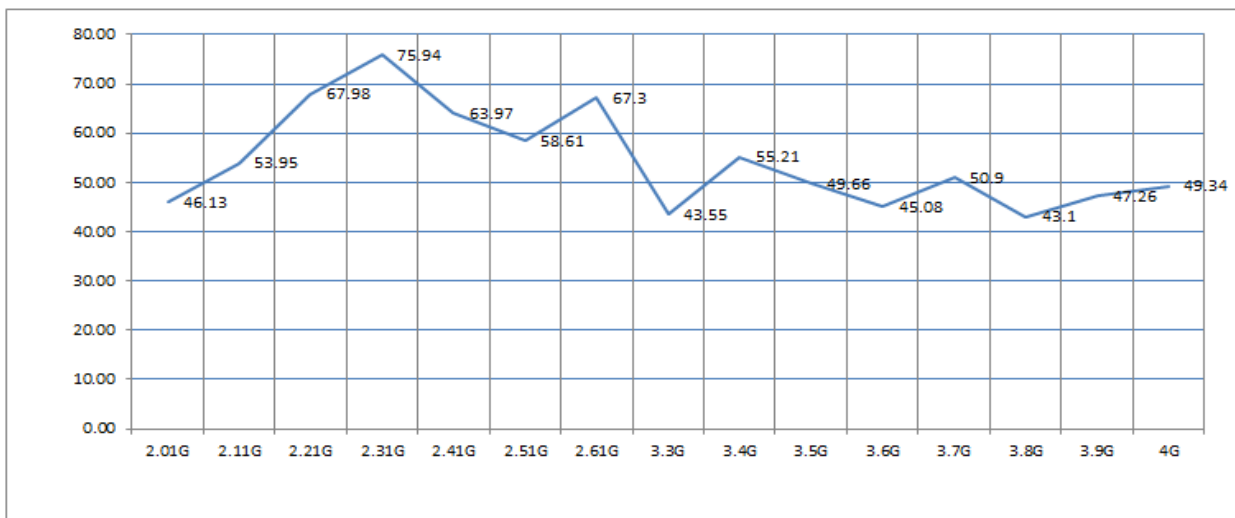

4000.00MHZ-6000.000MHZ Efficiency

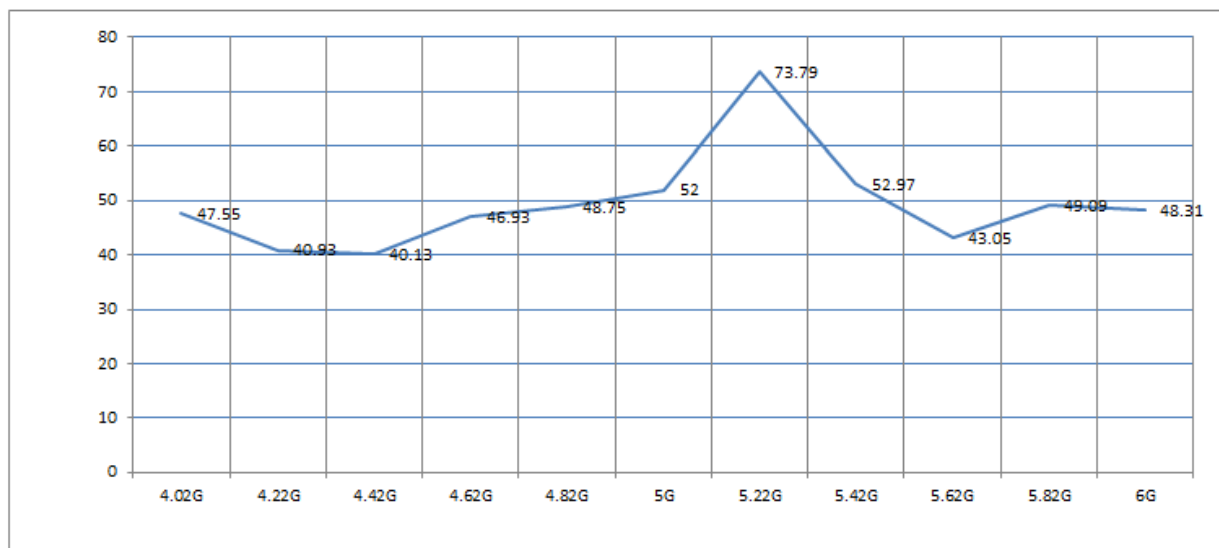

Frequency (MHz)	600	824	960	1710	1850	2150	2690	3500	5000	6000
Efficiency (%)	60.5	54.08	42.06	57.94	65.61	62.09	72.72	49.66	52.00	48.31

● Gain

600.00MHZ-2000.000MHZ Gain

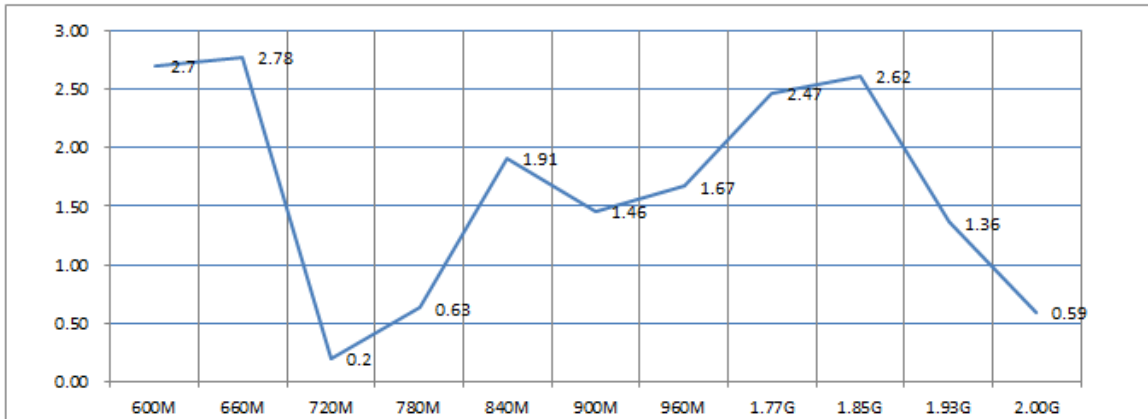

2000.00MHZ-4000.000MHZ Gain

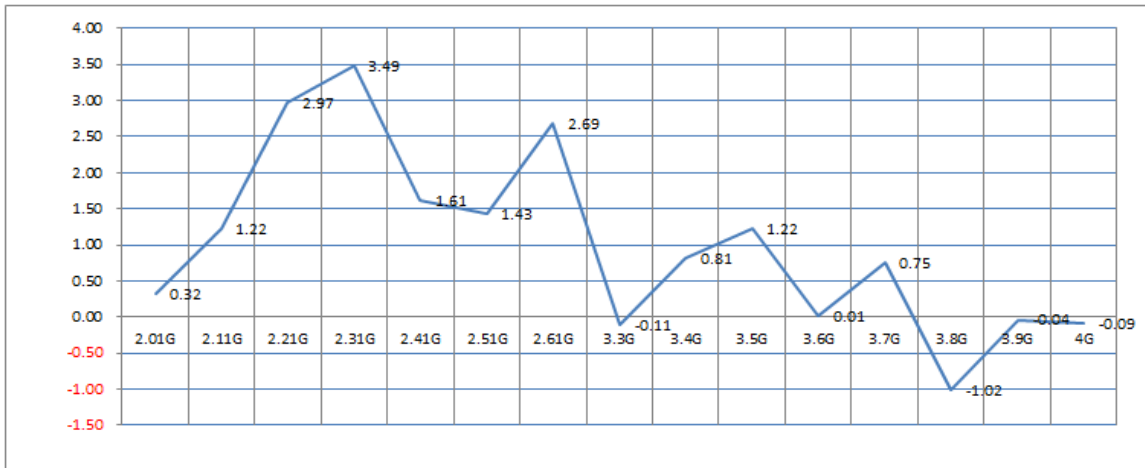

4000.00MHZ-6000.000MHZ Gain

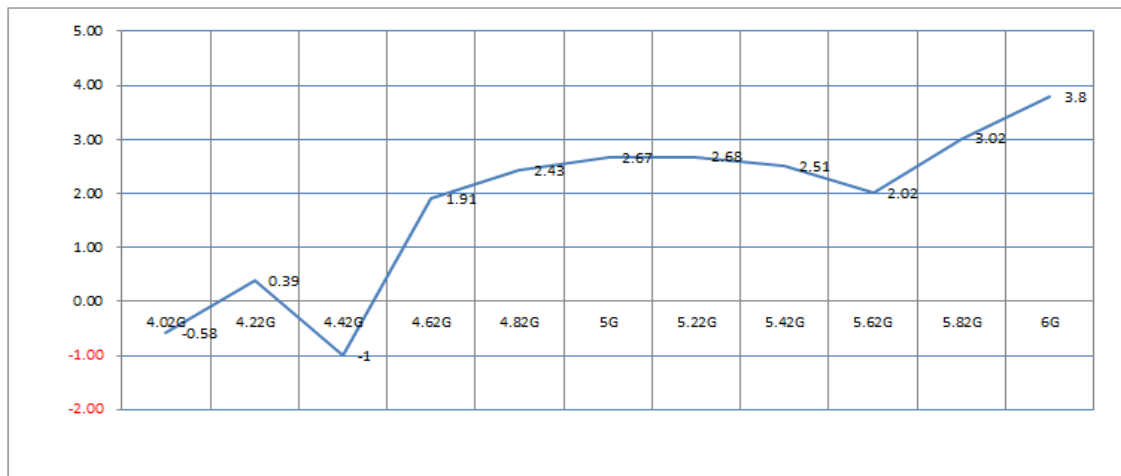

Frequency (MHz)	600	824	960	1710	1850	2150	2690	3500	5000	6000
Gain (dBi)	2.70	1.50	1.67	2.20	2.62	2.38	2.36	1.22	2.67	3.80

● Radiation Patterns



600MHzRight-Left View

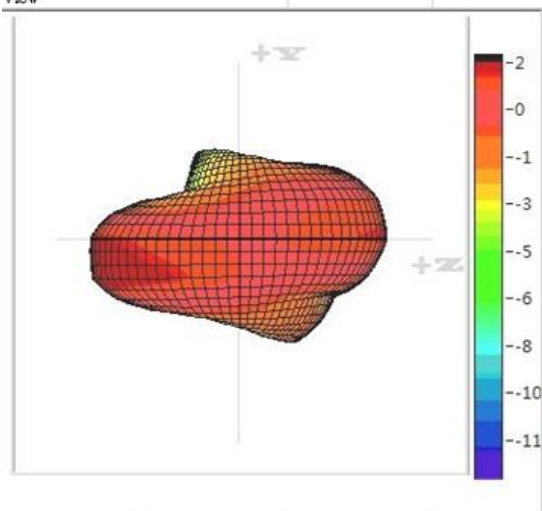

600MHz@Theta

90.0

Horizontal

Excel XY Plot (Value dB / Angle deg.)

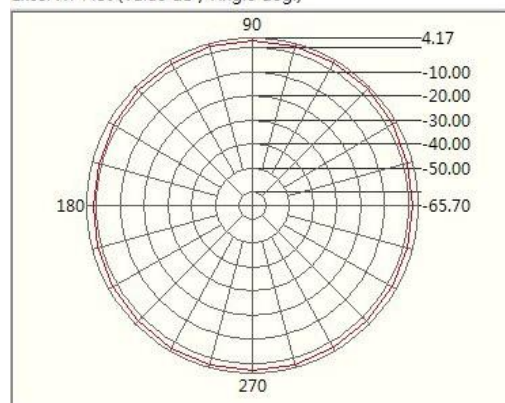

600MHz@Theta

90.0

Vertical

Excel XY Plot (Value dB / Angle deg.)

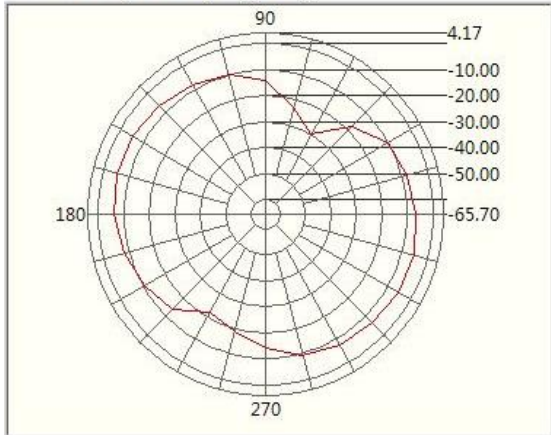

600MHz@Theta

90.0

Total

Excel XY Plot (Value dB / Angle deg.)

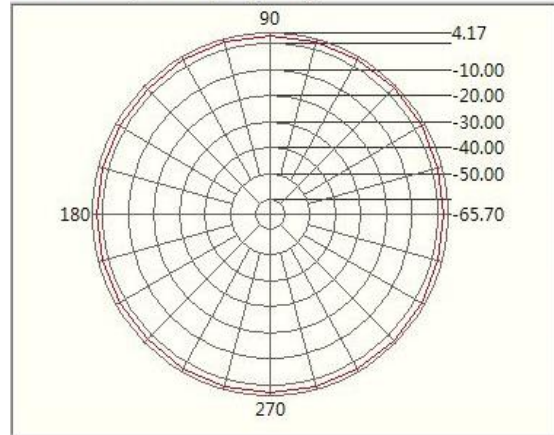

705MHzRight-Left

View

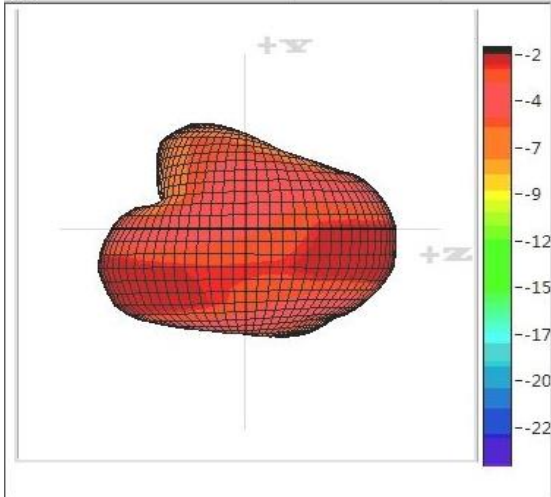

705MHz@Theta

90.0

Horizontal

Excel XY Plot (Value dB / Angle deg.)

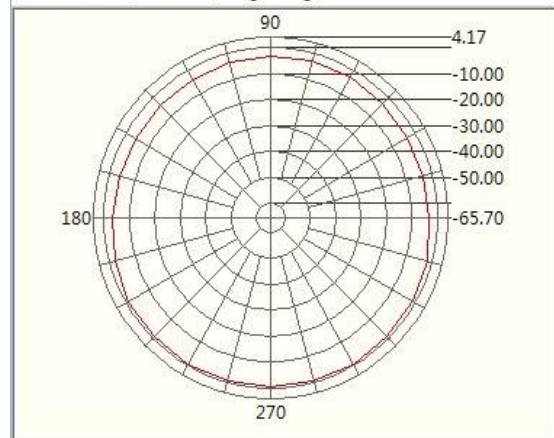

705MHz@Theta

90.0

Vertical

Excel XY Plot (Value dB / Angle deg.)

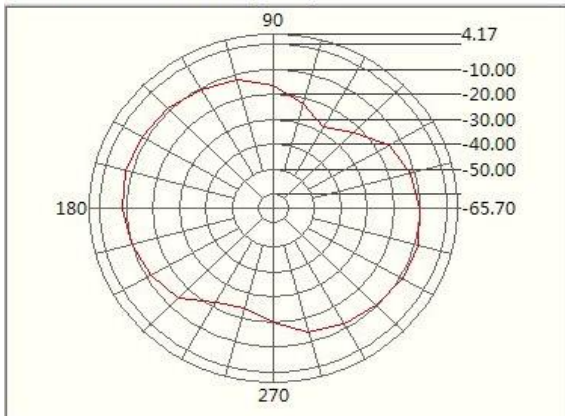

705MHz@Theta

90.0

Total

Excel XY Plot (Value dB / Angle deg.)

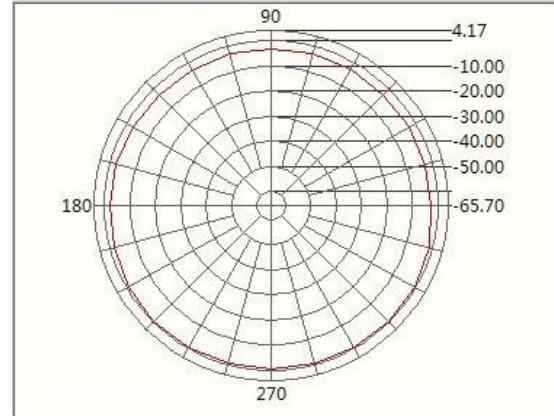

825MHzRight-Left
View

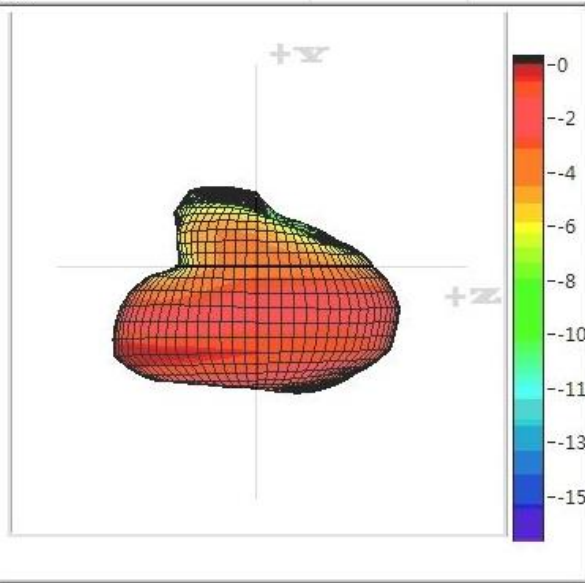

825MHz@Theta

90.0
Horizontal
Excel XY Plot (Value dB / Angle deg.)

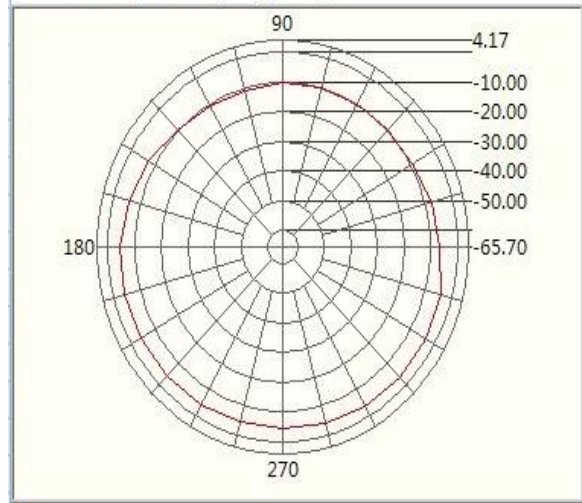

825MHz@Theta

90.0
Vertical
Excel XY Plot (Value dB / Angle deg.)

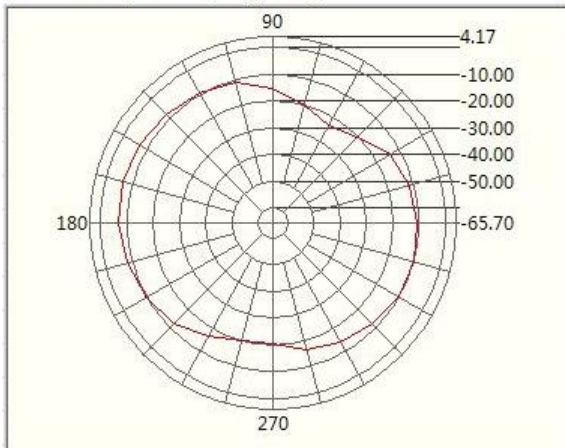

825MHz@Theta

90.0
Total
Excel XY Plot (Value dB / Angle deg.)

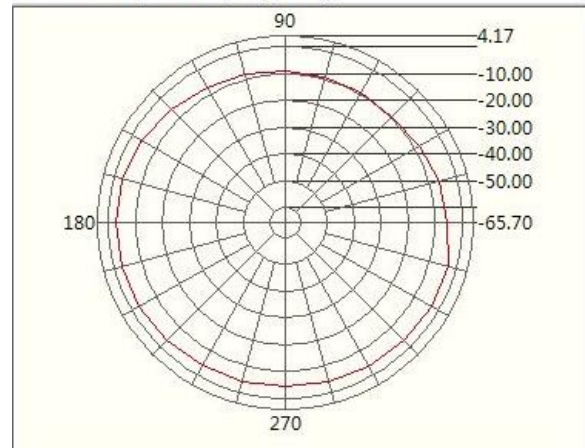

960MHzRight-Left
View

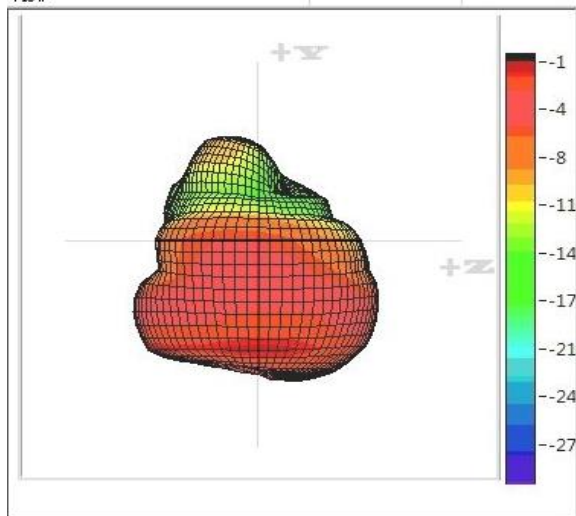

960MHz@Theta
90.0

Horizontal
Excel XY Plot (Value dB / Angle deg.)

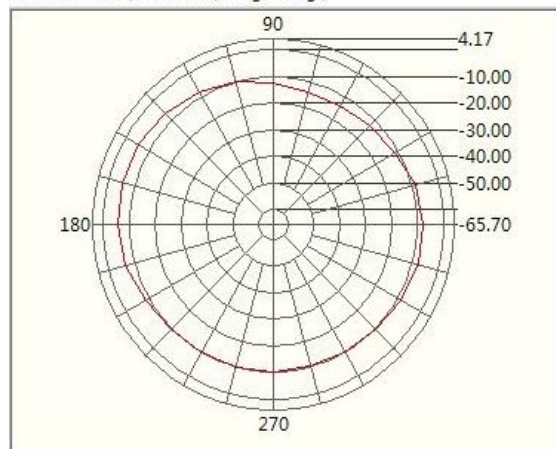

960MHz@Theta

90.0

Vertical

Excel XY Plot (Value dB / Angle deg.)

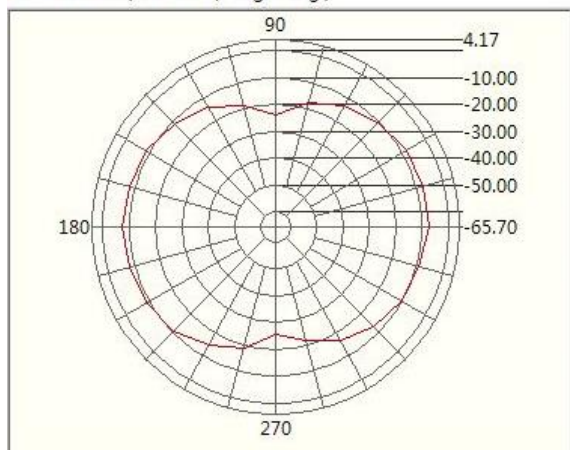

960MHz@Theta

90.0

Total

Excel XY Plot (Value dB / Angle deg.)

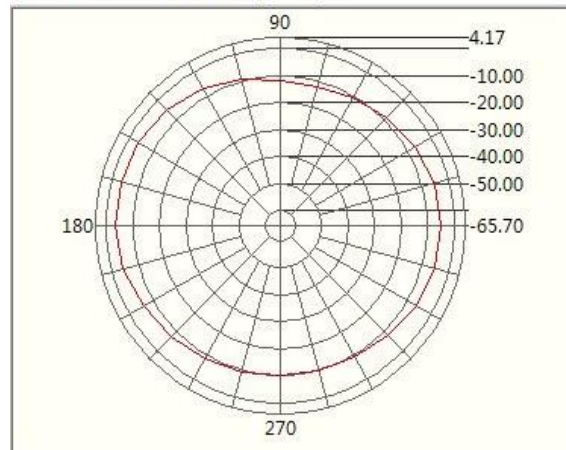

1.71GHzRight-Left

View

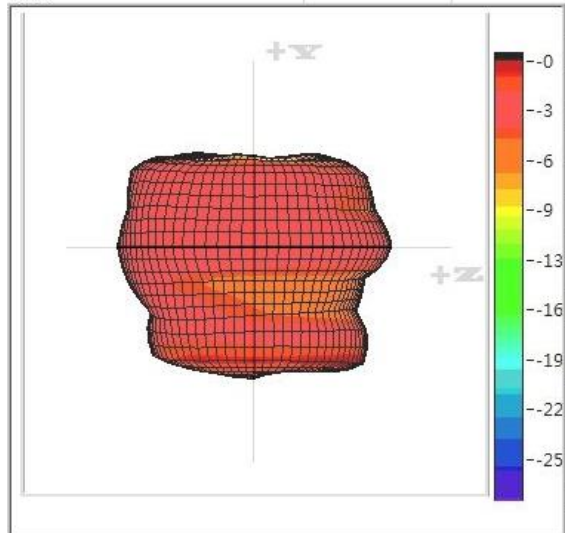

1.71GHz@Theta

90.0

Horizontal

Excel XY Plot (Value dB / Angle deg.)

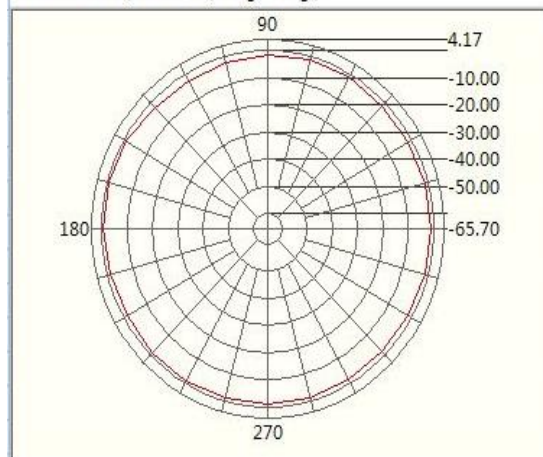

1.71GHz@Theta

90.0

Vertical

Excel XY Plot (Value dB / Angle deg.)

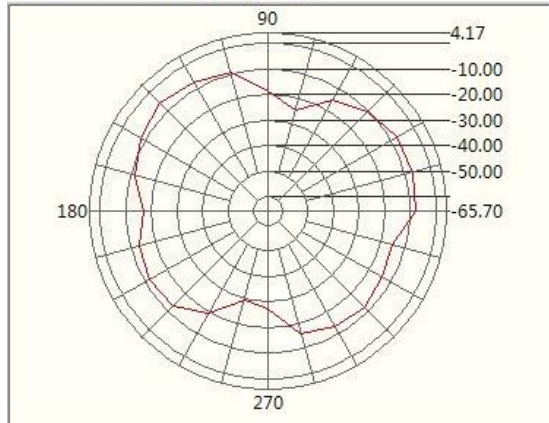

1.71GHz@Theta

90.0

Total

Excel XY Plot (Value dB / Angle deg.)

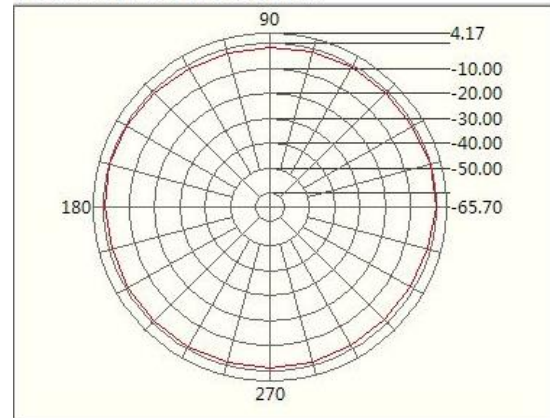

2.69GHzRight-Left

View

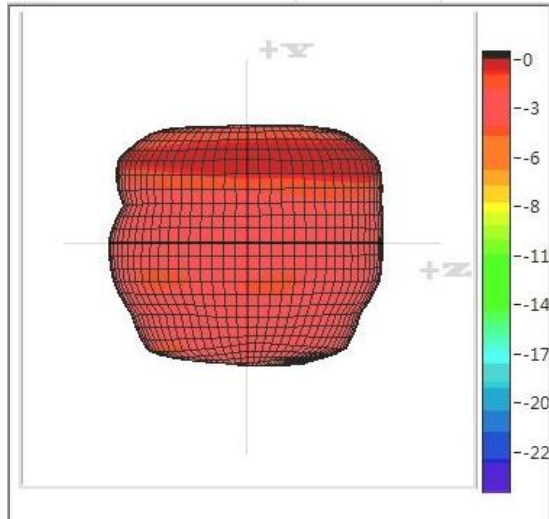

2.69GHz@Theta

90.0

Horizontal

Excel XY Plot (Value dB / Angle deg.)

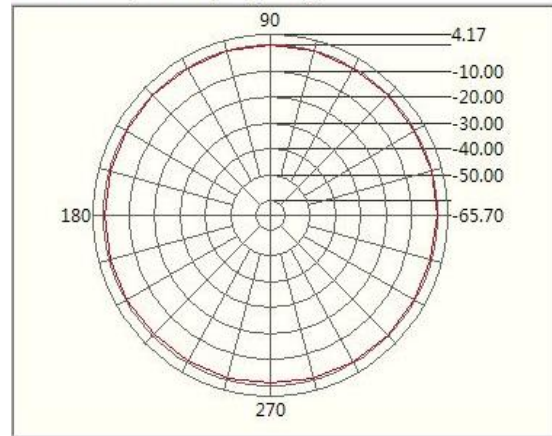

2.69GHz@Theta

90.0

Vertical

Excel XY Plot (Value dB / Angle deg.)

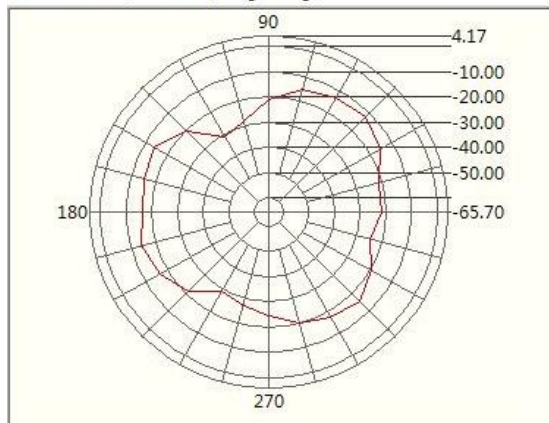

2.69GHz@Theta

90.0

Total

Excel XY Plot (Value dB / Angle deg.)

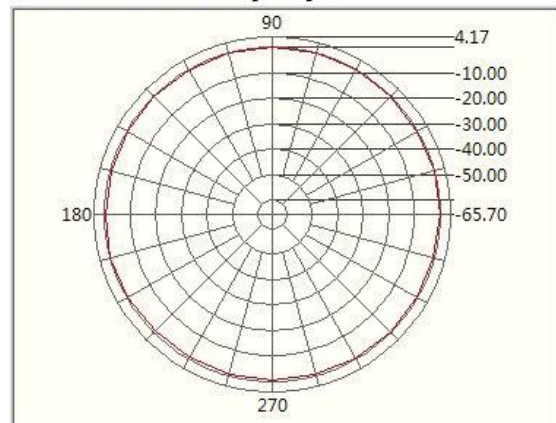

3.4GHzRight-Left
View

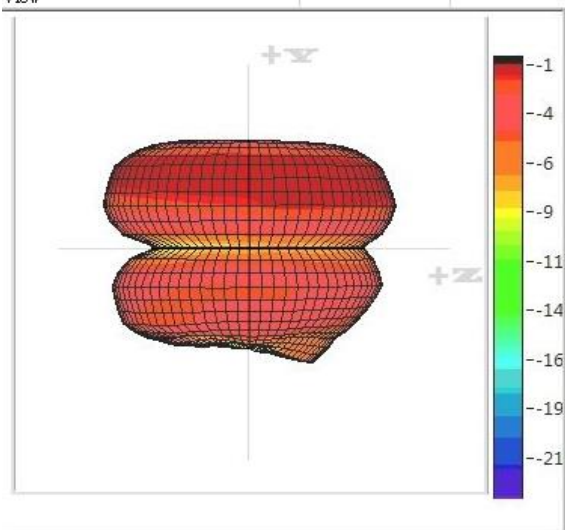

3.4GHz@Theta
90.0

Horizontal
Excel XY Plot (Value dB / Angle deg.)

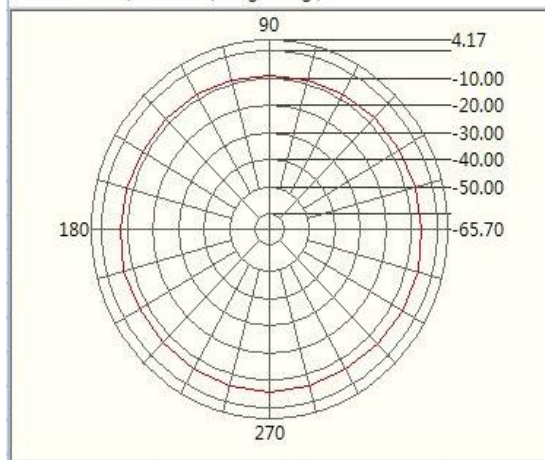

3.4GHz@Theta
90.0

Vertical
Excel XY Plot (Value dB / Angle deg.)

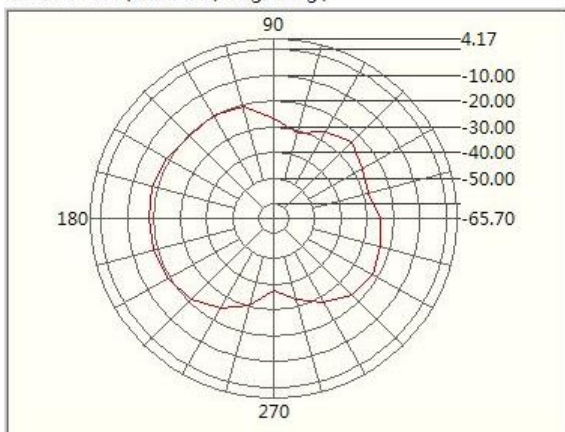

3.4GHz@Theta
90.0

Total
Excel XY Plot (Value dB / Angle deg.)

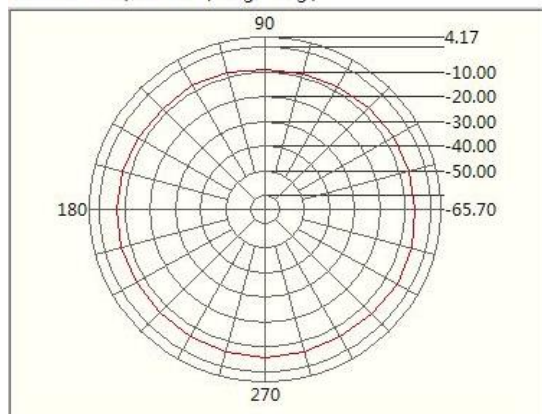

4.8GHzRight-Left
View

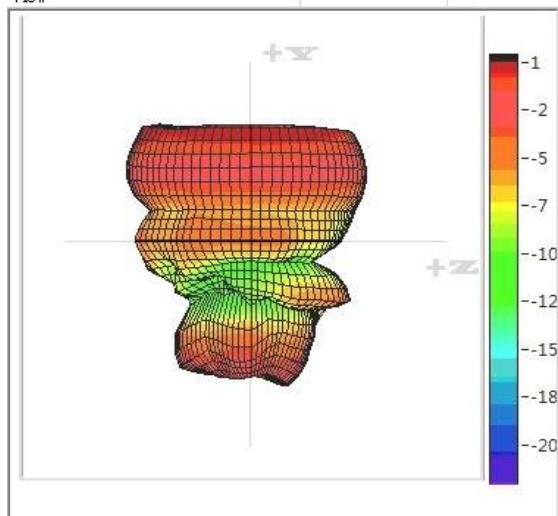

4.8GHz@Theta
90.0

Horizontal
Excel XY Plot (Value dB / Angle deg.)

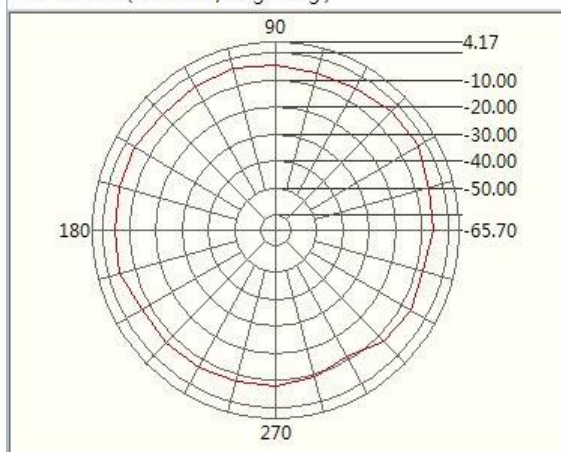

4.8GHz@Theta
90.0
Vertical
Excel XY Plot (Value dB / Angle deg.)

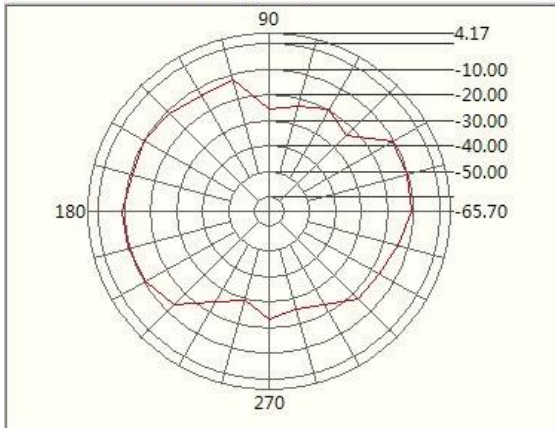

4.8GHz@Theta
90.0
Total
Excel XY Plot (Value dB / Angle deg.)

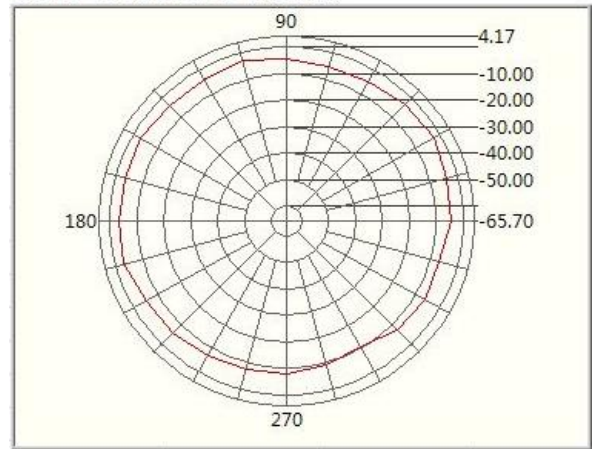

5.8GHzRight-Left
View

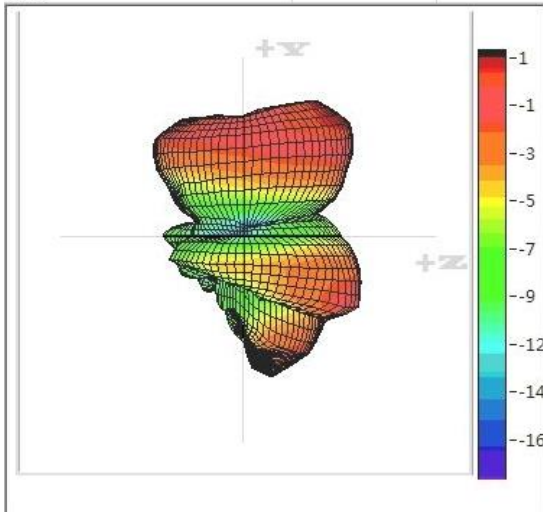

5.8GHz@Theta
90.0
Horizontal
Excel XY Plot (Value dB / Angle deg.)

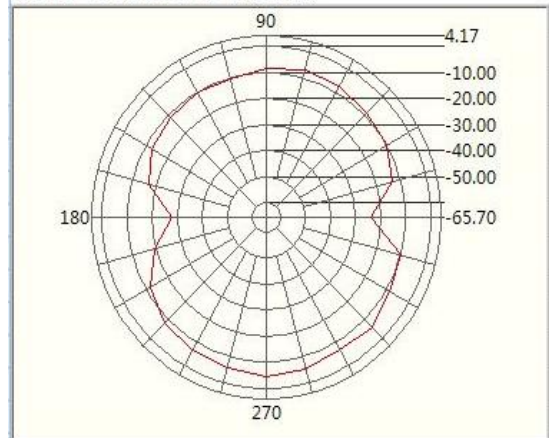

5.8GHz@Theta
90.0
Vertical
Excel XY Plot (Value dB / Angle deg.)

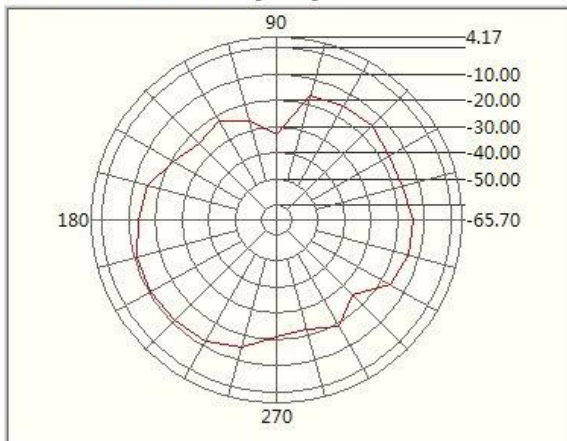

5.8GHz@Theta
90.0
Total
Excel XY Plot (Value dB / Angle deg.)

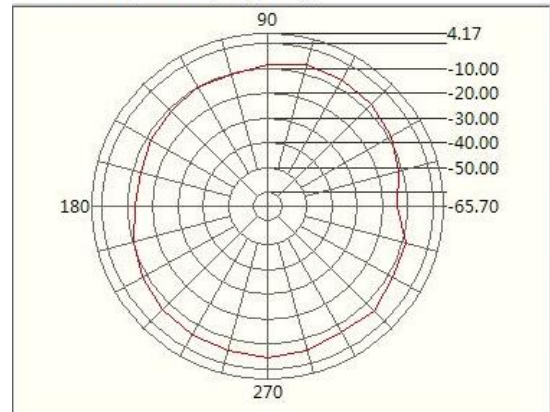

5 Product Size

