

mEZ Product Options:

1. Ready-to-Use products
 2. Do-It-Yourself.
- Manufacture assistance is provided

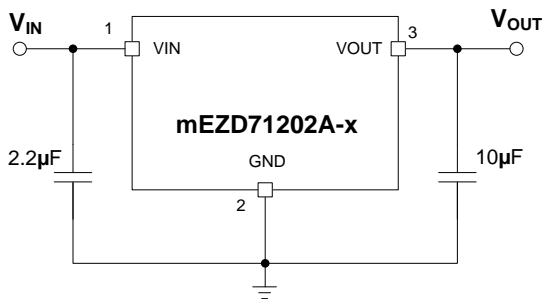

Typical Application Circuit

Efficiency vs. Load Current

$V_{IN}=12V, V_{OUT} = 1V - 5V$

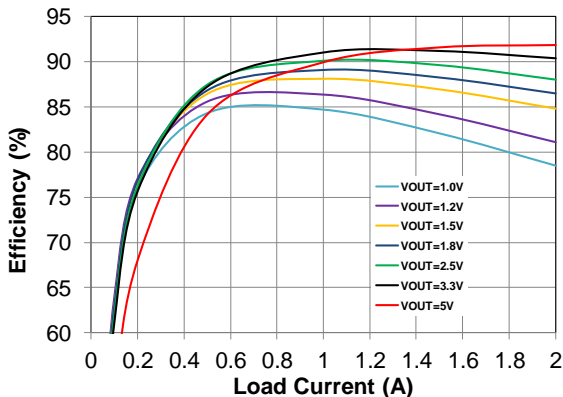

FEATURES

- 4.5V to 24V Wide Operating Input
- 2A Load Current
- Hiccup Short-Circuit Protection
- Over-/Under-Voltage Protection
- Over-Current Protection
- Over-Temperature Protection
- Open Design Files and BOM

ORDERING INFORMATION

Part Number	Input Voltage (V)	Output Voltage (V)	Output Current (A)
MEZD71202A-X	A - F: 4.5 - 24 G: 6.5 - 24	1, 1.2, 1.5, 1.8, 2.5, 3.3, 5	2
Output Voltage Options			
A = 1.0V	B = 1.2V	C = 1.5V	D = 1.8V
E = 2.5V	F = 3.3V	G = 5.0V	

mEZD712xx FAMILY PRODUCTS

Part Number	Input Voltage (V)	Output Voltage (V)	Output Current (A)
mEZD71201A-X	4.5 - 24	1, 1.2, 1.5, 1.8, 2.5, 3.3, 5	1
mEZD71202A-X	4.5 - 24	1, 1.2, 1.5, 1.8, 2.5, 3.3, 5	2
mEZD71203A-X	4.5 - 16	1, 1.2, 1.5, 1.8, 2.5, 3.3	3
mEZD71210A-A	4.5 - 17	1	10

ELECTRICAL CHARACTERISTICS

Input Voltage Range	V_{IN_MIN} higher than V_{OUT} by 1V	4.5 or 6.5 to 24V
Output Voltage Set Accuracy		$\pm 2.5\%$ (Typ.)
Output Voltage Ripple	$V_{IN}=12V, V_{OUT}=3.3V$, Full Load	33.6mV
Line Regulation	V_{IN} from MIN to MAX, $V_{OUT}=3.3V$	$\pm 1\%$ (Typ.)
Load Regulation	I_{OUT} from MIN to MAX, $V_{OUT}=3.3V$	$\pm 1\%$ (Typ.)
Switching Frequency	Typical Switching Frequency	400kHz
Short-Circuit Protection	Short Output to Ground	Hiccup Mode
Operating Temperature Range		-40 to 85°C
Over-Temperature Protection	OTP	150°C
Rise Time	V_{OUT} from 0% to 90%	0.75ms (Typ.)
Calculated MTBF	MIL-HDBK-217F	4185x10 ³ hrs

NOTE: All electrical characteristics are tested under 25°C ambient temperature, $V_{IN}=12V$ unless otherwise noted.

DO-IT-YOURSELF SCHEMATIC

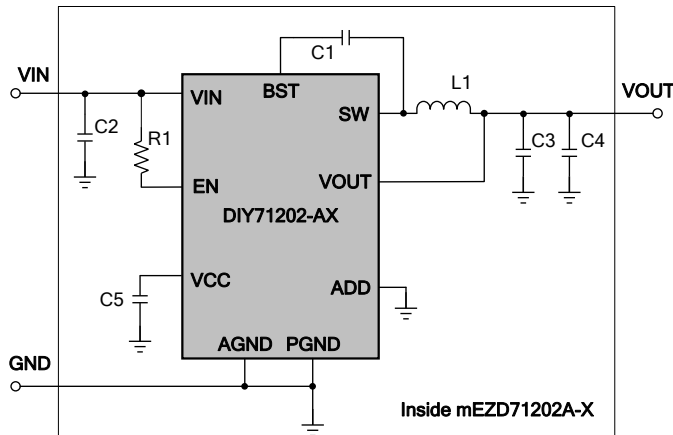

POWER DERATING

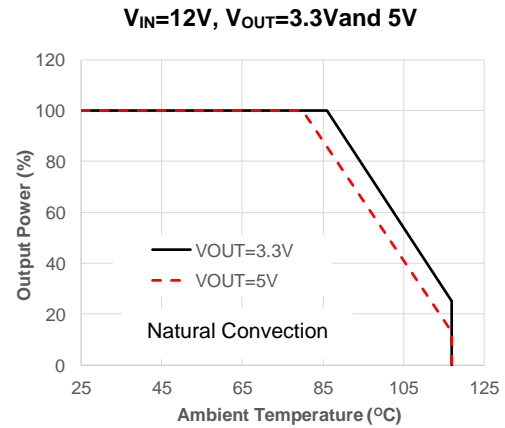

BILL OF MATERIALS

Item	Qty	RefDes	Value	Description	Package	Manufacturer	Manufacturer P/N
1	1	C1	0.22 μ F	Ceramic Cap., 16V, X5R	0402	muRata	GRM155R61C224KA12D
2	1	C2	4.7 μ F	Ceramic Cap., 50V, X7R	1206	muRata	GRM31CR71H475KA12L
3	2	C3, C4	22 μ F	Ceramic Cap., 10V, X7T/X5R	0805	muRata	GRM21BD71A226ME44L/ GRM21BR61A226ME51L
4	1	C5	1 μ F	Ceramic Cap., 10V, X5R	0402	muRata	GRM155R61A105KE01D
5	1	L1*	3.3 μ H	Indc 4.1A, DCR 27.3m Ω	5.5x5x3mm	Panasonics	ETQP3M3R3KVP
6	1	R1	499k Ω	Film Res., 1%	0402	Yageo	RC0402FR-07499KL
7	1	P1	3-pin	3-pin male connector, right angle	Bulk	MYIC	MPS010SRRA-3
8	1	U1		Synchronous Step-Down Converter	FCQFN3x3-16	MPS	DIY71202-AX**

* Or equivalent. ** -X Output voltage options (A: 1.0V, B: 1.2V, C: 1.5V, D: 1.8V, E: 2.5V, F: 3.3V, G: 5.0V)

PRODUCT PACKAGE AND DIMENSIONS

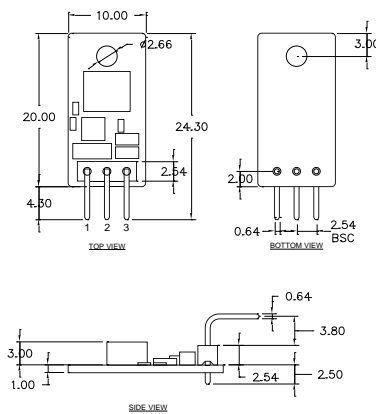

Pin	Designation	Function
1	VIN	Input Voltage
2	GND	Power Ground
3	VOUT	Output Voltage

NOTE:
Contact factory for different sizes of the boards (Quantity>2k).

For more information, Gerber files, and PCB layout, please contact mEZsupport@monolithicpower.com