



DB2605 EV Charging Controller

Datasheet

Rev 1.0.5, Nov 2024



Contents

Contents	2
1 Overview	3
1.1 HomePlug Green PHY	3
1.2 Charge Software Stack	3
1.3 Hardware Security Module	3
1.4 Diagram	3
1.5 Host Interface	4
2 Information	5
2.1 General	5
2.2 Pin Definitions	5
2.3 Power-on Configuration	6
2.4 Form Factor	7
2.5 Recommended Footprint	8
2.6 Recommended Solder Paste Footprint	9
2.7 Recommended Reflow Information	9
3 Electrical Characteristics	10
3.1 Recommended Operating Rating	10
3.2 Environment	10
3.3 DC Switching Thresholds	10
3.4 Current Consumption	11
4 Applications	11
4.1 Pilot Signal managed by Host Module	11
4.2 Pilot Signal Managed by DB2605	12
5 Reference Designs	12
5.1 Control Pilot Signal Generation	12
5.2 Control Pilot PWM Voltage Measurement	12
5.3 Proximity Pilot Generation and Measurement	13
5.4 Zero Crossing Circuit	13
5.5 HPGP Coupler	13
6 Packaging Information	14
7 Marking	14
8 Ordering	14
9 Design and Development	15
Legal Information	16
Contacting Dropbeats Technology	16
Revision History	16

1 Overview

The DB2605 EV Charging Controller is the core unit of a Supply Equipment Communication Controller (SECC) that manages EV Combined Charging System (CCS) AC high-level charging and basic charging.

The DB2605 EV Charging Controller is equipped with a Qualcomm QCA700X and a powerful MCU that runs RTOS with a complete ISO 15118-2/20 software stack and an optional IEC 61851 stack.

1.1 HomePlug Green PHY

The DB2605 fully supports HomePlug Green PHY Spec 1.1 (IEEE 1901). HPGP features:

- Spectrum: 2 – 30 MHz
- Max PHY rate: 10Mbps
- Modulation: OFDM
- Subcarriers: 917
- Subcarrier space: 24.414kHz
- ROBO: 4Mbps (5x repeat code), 5Mbps (4x repeat code), 10Mbps (2x repeat code)

1.2 Charge Software Stack

The DB2605 complies with

- ISO 15118-3
- ISO 15118-2/20 AC EIM and PnC
- ISO 15118-20 Bidirectional charging with security

1.3 Hardware Security Module

- Security certification: CC EAL4+ (HW + JCOP), FIPS 140-2 L3
- ECC crypto curves: ECC NIST (192 to 521 bit)/ed448
- Secure key storage: up to 50k bytes

1.4 Diagram

Figure 1 shows controller components as well as necessary connections and external components.

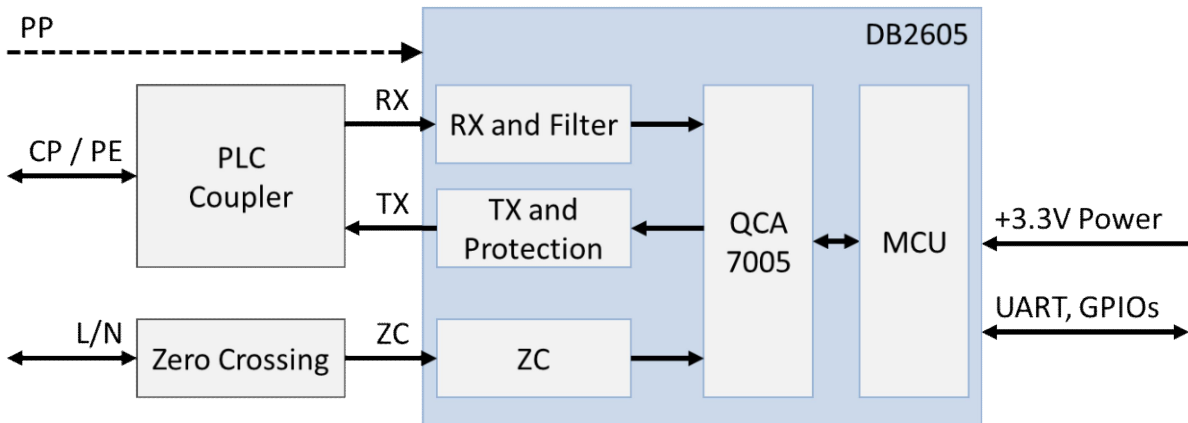

Figure 1 – DB2605 Block Diagram

All DB2605 components are protected by a metal shield. Information about the controller is printed on a high-temperature label on this shield.

1.5 Host Interface

The DB2605 connects to a host module via a UART interface, a reset pin, and a boot pin.

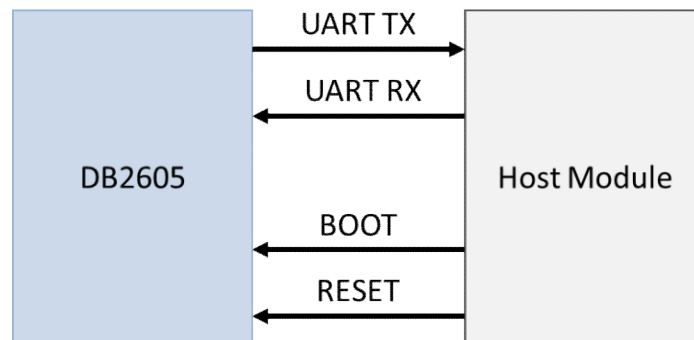

Figure 2 – Block Diagram of UART Pins

UART serial port setting: 115200bps; 8-N-1

2 Information

2.1 General

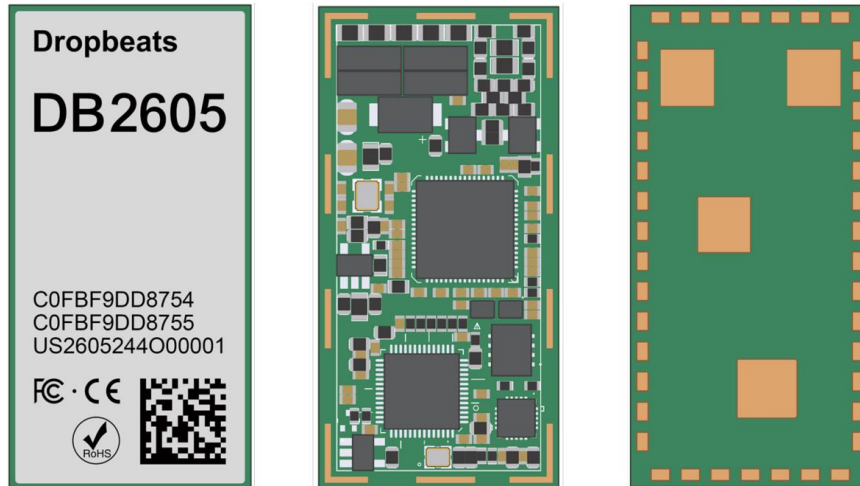

Figure 3 – Images of DB2605 EV Charging Controller

2.2 Pin Definitions

Pin	Name	Type	Usage
1	GND	P	Ground
2	RX-	IA	Power line coupling transformer Rx-
3	RX+	IA	Power line coupling transformer Rx+
4	TX-	OA	Power line coupling transformer Tx-
5	TX+	OA	Power line coupling transformer Tx+
6	GND	P	Ground
7	ZC_IN	IA	Power line zero crossing in. If not used, connect to ground.
8	GND	P	Ground
9	PWM	O	PWM control pilot (CP) output
10	GND	P	Ground
11	ADC_CP	IA	Control pilot ADC
12	ADC_PP	IA	Proximity pilot ADC
13	GND	P	Ground
14	UART0_TX	O	UART0 Tx
15	UART0_RX	I	UART0 Rx
16	USB_DP	I/O	Reserved, USB DP
17	USB_DM	I/O	Reserved, USB DM
18	GP25	I/O	Reserved
19	GP26	I/O	Reserved
20	GP27	I/O	Reserved
21	GP28	I/O	Reserved
22	PSGD	I	PWM - Control Pilot Signal Generation/Detection setting
23	GP30	I/O	Reserved

Pin	Name	Type	Usage
24	GP31	I/O	Reserved
25	GP32	I/O	Reserved
26	GP33	I/O	Reserved
27	GP34	I/O	Reserved
28	GND	P	Ground
29	Vdd	P	Power supply, 3.3V
30	GND	P	Ground
31	I2C0_SDA	I/O	Reserved
32	I2C0_SCL	I/O	Reserved
33	CAN_TX	I/O	Reserved
34	CAN_RX	I/O	Reserved
35	UART1_TX	O	UART1 Tx
36	UART1_RX	I	UART1 Rx
37	GND	P	Ground
38	/Reset	I	Power-on reset. Active low power-on-reset input.
39	BOOT	I	Boot mode setting
40	GND	P	Ground
41	GND	P	Ground
42	GND	P	Ground
TPAD1	GND	P	Ground
TPAD2	GND	P	Ground
TPAD3	GND	P	Ground
TPAD4	GND	P	Ground

2.3 Power-on Configuration

Two pins of the DB2605 are read at boot time to get the desired configuration.

Pin	Function	Description
PSGD	Pilot signal generation/ detection setting	High: Enable PWM generation and detection Low: Disable
BOOT	Boot mode	High: Boot from UART0 (pins 14/15). This mode is mainly used for firmware upgrade. Low: Launch application image from flash

2.4 Form Factor

Width * Length * Height: 20.32 * 40.64 * 4 mm

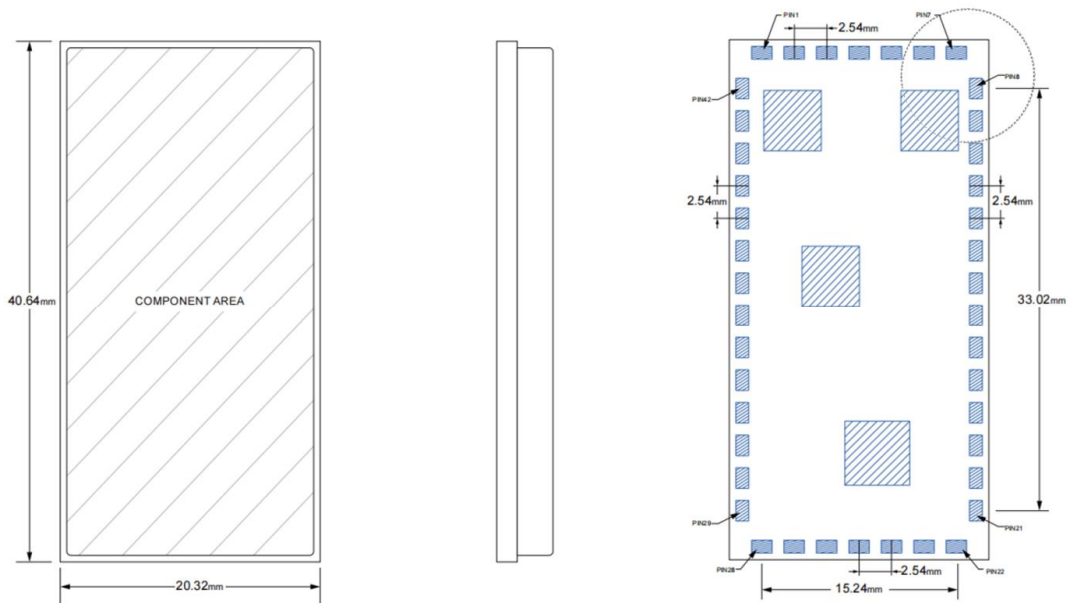

Figure 4 – DB2605 Form Factor



2.5 Recommended Footprint

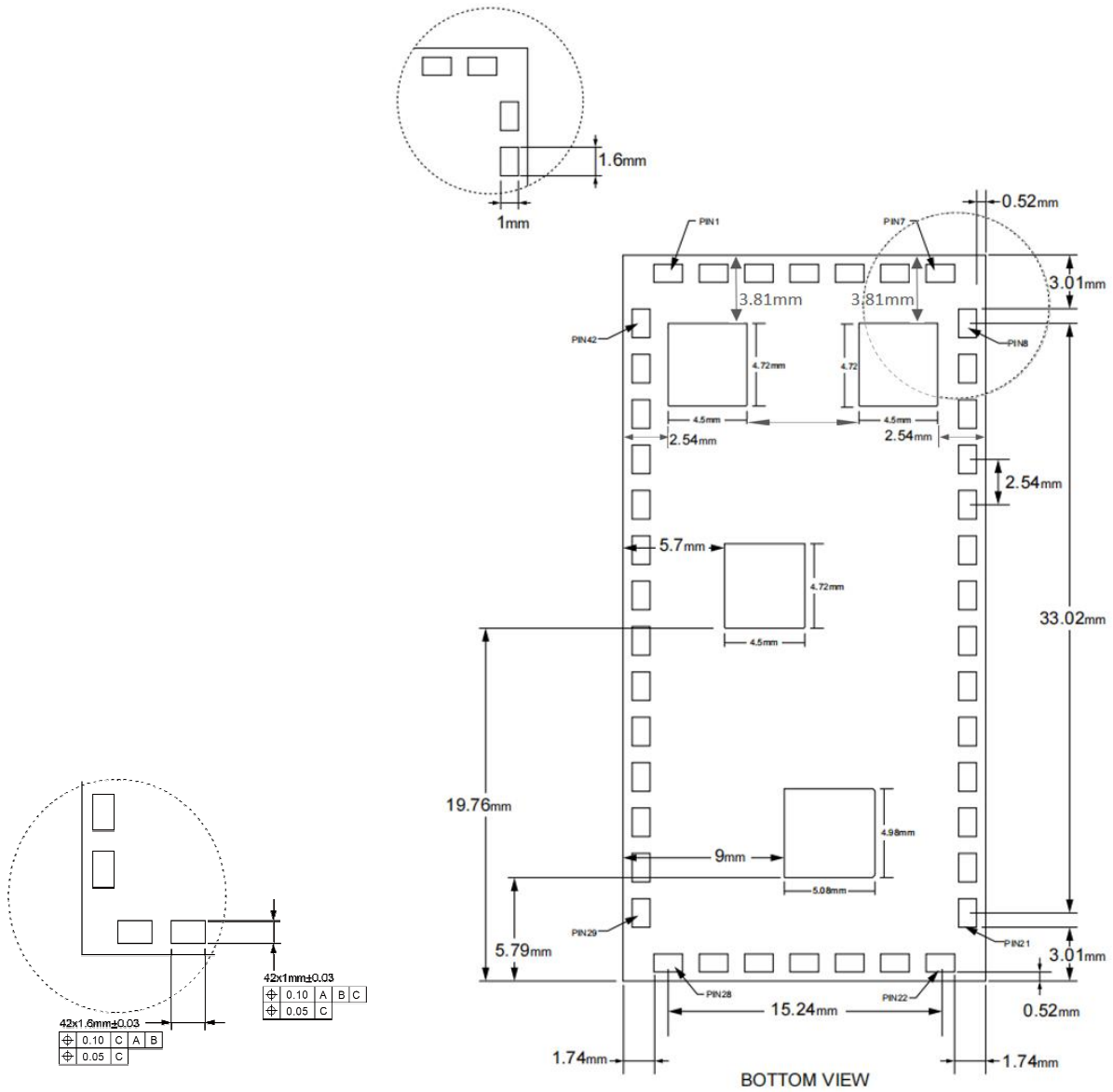

Figure 5 – Recommended Footprint

Notes:

1. Top view of footprint, looking through the DB2605 from above
2. DB2605 outline shows nominal dimensions; tolerance is not included
3. All dimensions in mm
4. Height is about 4mm
5. Pads are all the same size
6. Distances between pads are equal

2.6 Recommended Solder Paste Footprint

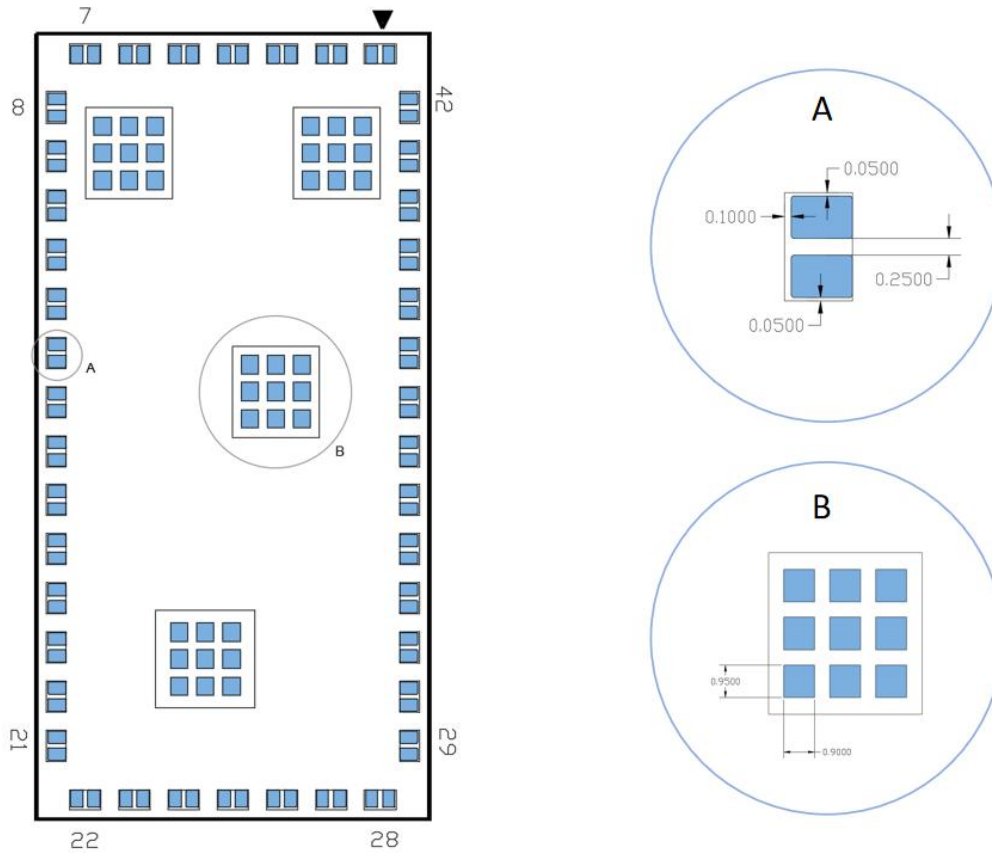

Figure 6 – Recommended Solder Paste Footprint

2.7 Recommended Reflow Information

	Low Limit	High Limit	Units
Max Rising Slope (Target=2.5)	1	5	Degrees/Second
Slope1 (Target=2.3)	0.5	4	Degrees/Second
Between 180.0 and 220.0			
Max Falling Slope	-3	-1	Degrees/Second
Soak Time 150-180C	60	100	Seconds
Time Above Reflow - 220C	30	90	Seconds
Peak Temperature	235	250	Degrees Celsius

Reflow Profile Setting Example:

Degree Celsius										
Zone	1	2	3	4	5	6	7	8	9	10
	150	160	180	180	180	180	200	220	235	260
Conveyor Speed (cm/min):	90									

Reflow Profile Example:

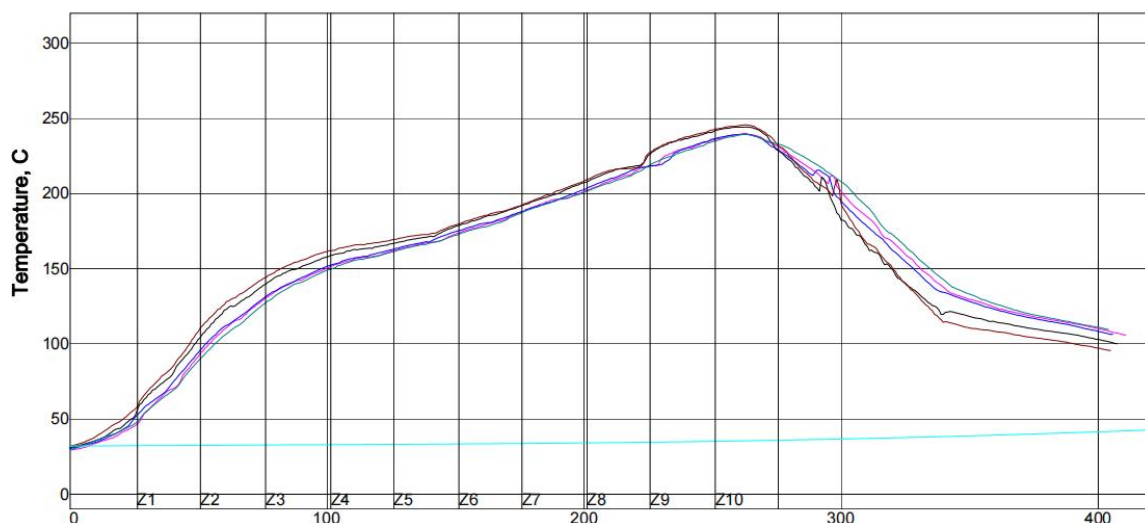

Figure 7 – Reflow Profile Example

3 Electrical Characteristics

3.1 Recommended Operating Rating

Symbol	Parameter	Min	Typ	Max	Units
Vdd	Power Supply	3.13	3.3	3.46	V

3.2 Environment

Environmental Condition	
Operating Temperature	-40 – 85 °C
Storage Temperature	-40 – 105 °C

3.3 DC Switching Thresholds

Symbol	Parameter	Test Conditions	Min	Max	Units
VIL	Low-level input voltage		—	0.3*Vdd	V
VIH	High-level input voltage		0.7*Vdd	—	V



VOL	Low-level output voltage	IOL = 4 mA, 12 mA ¹	—	0.4	V
VOH	High-level output voltage	IOH = -4 mA, -12 mA ²	2.4	—	V
IOZ	High-impedance output current	Gnd ≤ VI ≤ Vdd	-1	+1	μA

- ¹ IOL = 12 mA for all GPIOs
IOL = 4 mA for all other interfaces
- ² IOH = -12 mA for all GPIOs
IOH = -4 mA for all other interfaces

3.4 Current Consumption

Parameter	Value
Max power dissipation	300mA
Typical power dissipation	200mA

4 Applications

4.1 Pilot Signal managed by Host Module

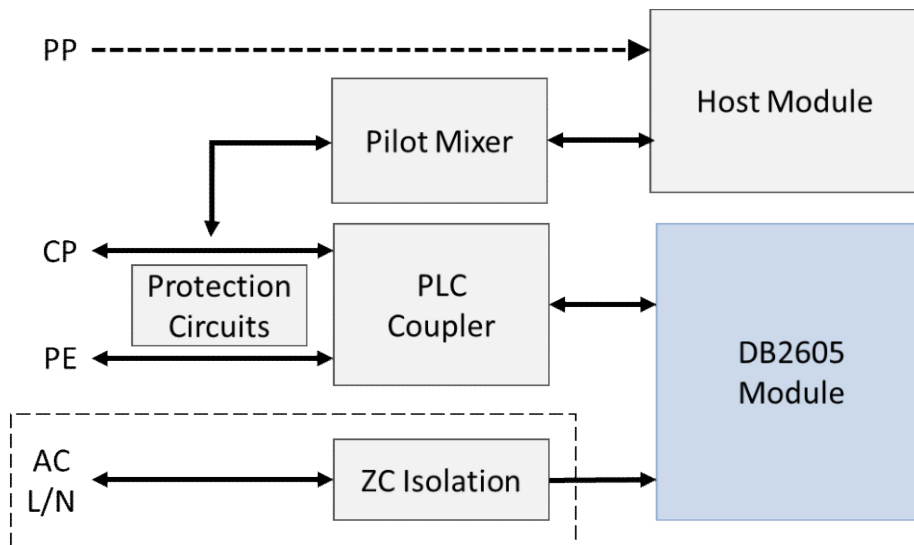

Figure 8 – Control Pilot Signal Managed by Host Module

Note: AC line zero crossing detection requires an external optical coupler and filter circuits.

4.2 Pilot Signal Managed by DB2605

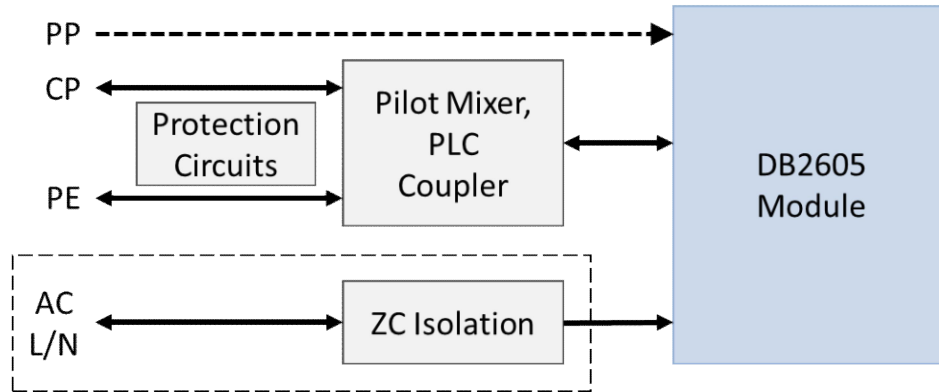

Figure 9 – Control Pilot Signal Managed by DB2605

Note: AC line zero crossing detection requires an external optical coupler and filter circuits.

5 Reference Designs

5.1 Control Pilot Signal Generation

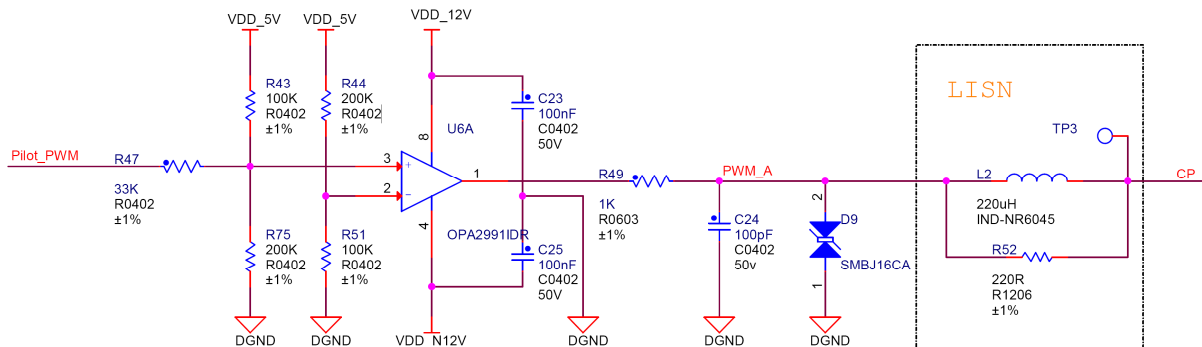

Figure 10 – Control Pilot Signal Generation

5.2 Control Pilot PWM Voltage Measurement

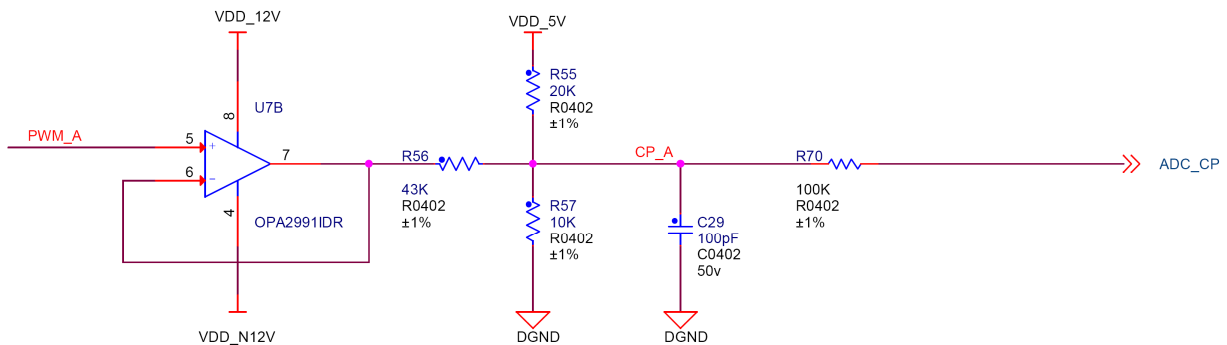

Figure 11 – Control Pilot PWM Voltage Measurement



5.3 Proximity Pilot Generation and Measurement

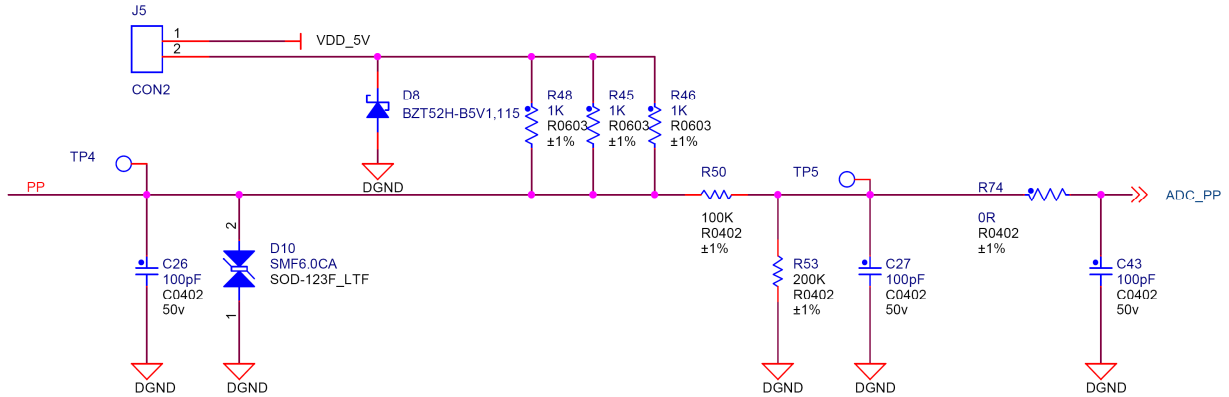

Figure 12 – Proximity Pilot Generation and Measurement

Note: In Europe AC fast charging (mode 3), +5V power may be inserted and monitored.

5.4 Zero Crossing Circuit

A zero crossing function may be used to synchronize other PLC devices for bandwidth management.

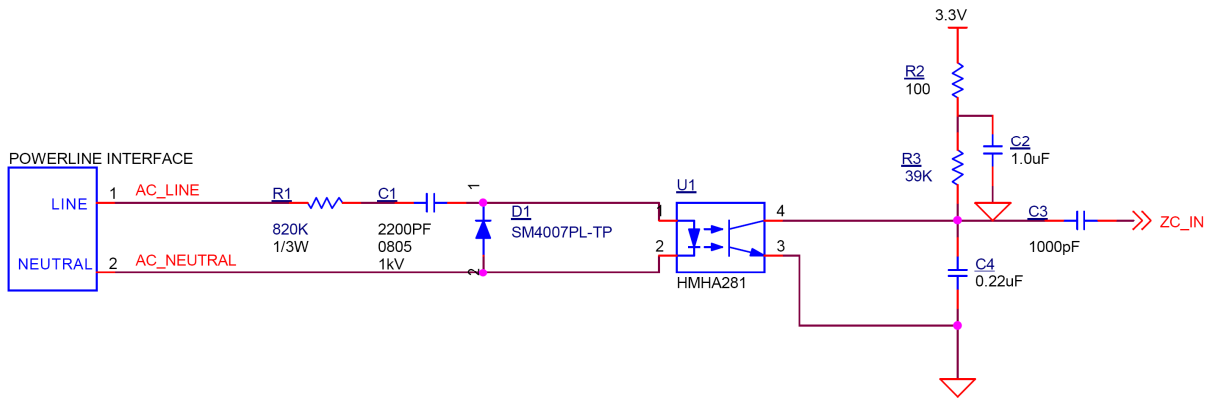

Figure 13 – HPGP Zero Crossing Circuit

5.5 HPGP Coupler

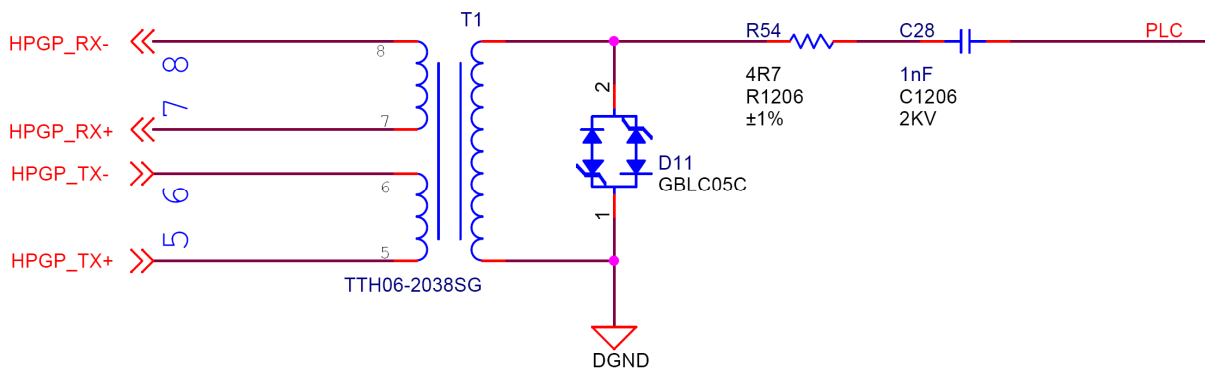

Figure 14 – HPGP Coupler Circuit

A coupling capacitor blocks the DC voltage present on the pilot wire. The component values may change after component optimization.

A 1:1:1 turn ratio transformer and a 4.7 Ω series resistor limit transient current and set the output impedance to about 6 Ω . This current-limiting resistor value may be adjusted slightly to trim the transmitter output voltage amplitude.

A TVS diode is placed across the PLC coupling transformer to isolate the second stage circuitry and clamp surge voltage to a more acceptable level for the DB2605.

Recommended Coupler Transformer

Part No.	Vendor	Features	Description
TTH06-2038SG	Dropbeats	Industrial	AC EVSE Application

6 Packaging Information

The polystyrene carrier tape package contains 200 DB2605 per reel.

7 Marking

Each Controller is marked with the following data:

- Dropbeats brand
- Controller identifier DB2605
- HPGP Modem MAC address
- HOST MCU MAC address
- Serial Number
- Certification logos
- QR code with HPGP Modem MAC address

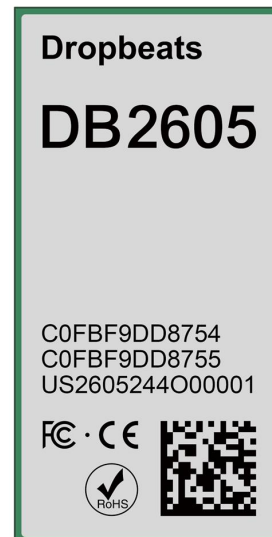

8 Ordering

Order Code	Chipset	Temperature Range	Interface	Applications
DB2605-AC-UN-U-V130	QCA7005-AL33	-40 – 85°C	UART	AC EVSE



9 Design and Development

Product	Description
DB2605 EV Charging HAT	DB2605 with jumpers and connector. A platform that allows evaluation, software development, and integration of the DB2605, the ISO 15118-2/20 AC charging solution.
DB2605 EV Charging Raspberry Pi Kit	DB2605 EV Charging HAT plus Raspberry Pi
DB2605 EV Charging Evaluation Kit	DB2605 EV Charging Raspberry Pi Kit extended to include EV coupler and EV simulator, which allow quick evaluation of EV charging designs

Legal Information

Copyright

Copyright 2024 Dropbeats Technology Co., Ltd. All rights reserved.

The information in this document is proprietary and confidential to Dropbeats Technology Co., Ltd., and for its customers' internal use. No part of this document may be reproduced or redistributed in any form without the express written consent of Dropbeats Technology Co., Ltd.

Disclaimer

None of the information contained in this document constitutes an express or implied warranty by Dropbeats Technology Co., Ltd. as to the sufficiency, fitness or suitability for a particular purpose of any such information or the fitness, or suitability for a particular purpose, merchantability, performance, compatibility with other parts or systems, of any of the products of Dropbeats Technology Co., Ltd., or any portion thereof, referred to in this document. Dropbeats Technology Co., Ltd. expressly disclaims all representations and warranties of any kind regarding the contents or use of the information, including, but not limited to, express and implied warranties of accuracy, completeness, merchantability, fitness for a particular use, or non-infringement.

In no event will Dropbeats Technology Co., Ltd. be liable for any direct, indirect, special, incidental or consequential damages, including, but not limited to, lost profits, lost business, or lost data resulting from any use of or reliance upon the information, whether or not Dropbeats Technology Co., Ltd. has been advised of the possibility of such damage.

Contacting Dropbeats Technology

Dropbeats Technology

123 Juli Road, Building 4, Shanghai, China

Tel: +86 (21) 5085-0752

Fax: +86 (21) 5085-0753

Document Information: document@drop-beats.com

Corporate Information: info@drop-beats.com

Technical Support: apps@drop-beats.com

Web Site: <https://www.drop-beats.com>

Revision History

Revision	Date	Descriptions
1.0.0	2024.4.24	Initial
1.0.1	2024.5.31	Changed document name to Datasheet.
1.0.2	2024.6.4	Changed document name "module" to "controller"
1.0.3	2024.7.6	Updated form factor
1.0.4	2024.7.18	Updated form factor
1.0.5	2024.11.8	Added bottom pads for soldering; added soldering paste footprint; added reflow profile setting.