



Entry Module XM131 Presence Datasheet v1.0



Abstract

The XM131 Entry Module is an integration ready Land Grid Array (LGA) module for compact commercial products. The module measures 18.6x15 mm and is optimized for presence and motion detection where low power consumption and cost is important.

The Entry Module XM131 is built around the Arm® 32-bit Cortex®-M0+ MCU from STMicroelectronics (STM32G071CUB6) and can be used as a stand-alone module where customer can embed their application on top of the Acconeer RSS (Radar System Software). It can also be used with an external host controller where communication to the module is via a register command protocol.

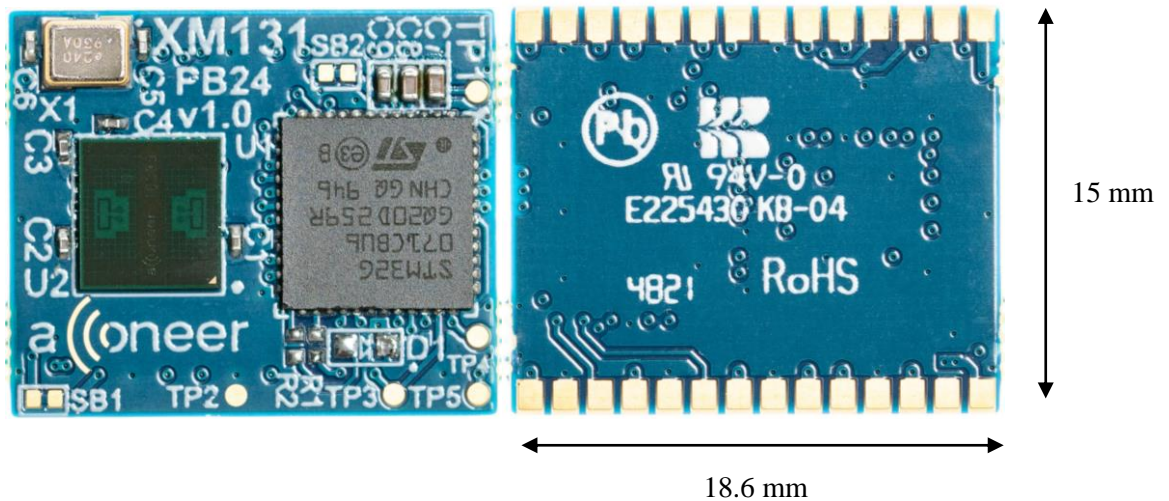

Figure 1. XM131 Top view (left) and XM131 bottom view (right).



Table of Content

1	Revision History	4
2	Functional description	5
2.1	Overview	5
2.2	Product features.....	5
2.3	Block diagram.....	6
2.4	Module board Land Grid Array description.....	7
2.5	Software options	9
3	Interfaces	10
3.1	Module supply input	10
3.2	System functions.....	10
3.3	Serial interfaces	10
3.4	I/O interfaces	10
3.5	Module reset.....	10
4	Electrical specifications	11
4.1	Absolute maximum ratings.....	11
4.2	Recommended operating conditions.....	11
4.3	Power consumption summary	12
4.4	RF specification.....	12
5	Reference design description XM131	13
5.1	Schematics & BOM	13
5.2	Component Placement Drawing.....	16
6	Mechanical specifications.....	17
6.1	Moisture Sensitivity Level and Recommended Reflow Profile	18
6.2	RoHS and REACH Statement.....	18
7	Reference documents	19
8	Abbreviations	20
	Disclaimer	21



1 Revision History

Revision	Comment
V1.0	Released version

This document applies to the following product:

Product name	Part number
XM131	XM131-TY



2 Functional description

2.1 Overview

The Entry Module XM131 Presence comes with A111 60 GHz PCR sensor with 32-bit ARM® Cortex™ M0+ MCU.

Optimized for easy integration with LGA solder pads support, formfactor of 18.6x15mm and single supply operating voltage 1.8 V.

The XM131 is delivered with a bootloader enabling customer to download Acconeer RSS software including SDK (Software Development Kit) for stand-alone usage where customer can embed their own application on top of Acconeer RSS software. Acconeer RSS software provides API to set A111 sensor configuration and to retrieve supported radar services and detector data.

XM131 offers support as well to act as controlled by external host through register command protocol on UART and I2C.

2.2 Product features

The Entry Module XM131 is based on Acconeer A111 pulsed coherent radar (PCR) and the STMicroelectronics M0+ MCU (STM32G071CUB6).

Entry Module XM131 features:

- A111 60 GHz Pulsed Coherent Radar (PCR) with integrated baseband, RF front-end and Antenna in Package (AiP)
- 32-bit ARM® Cortex™ M0+ MCU (STM32G071CUB6) 64 MHz clk speed, 128kB Flash; 36 kB RAM
- Form factor 18.6x15 mm
 - All components mounted on PCB top side and solder pads (LGA) on PCB bottom side
- Single supply operating voltage 1.8 V
- Operating temperature -40° to 85°C
- External I/F support - UART, I2C, GPIO, Reset
- SWD/JTAG for SW flash and debug.

The Entry Module XM131 presence is optimized for Presence and micro Motion detection:

- High precision presence & motion detection with configurable update frequency.
- Possible to recognize movement within configurable detection zones.

Easy integration:

- Entry Module XM131 can be integrated behind plastic or glass without any need for a physical aperture. See ref [6] *Hardware and physical integration guideline* for more information.
- LGA solder pads support for easy integration.



2.3 Block diagram

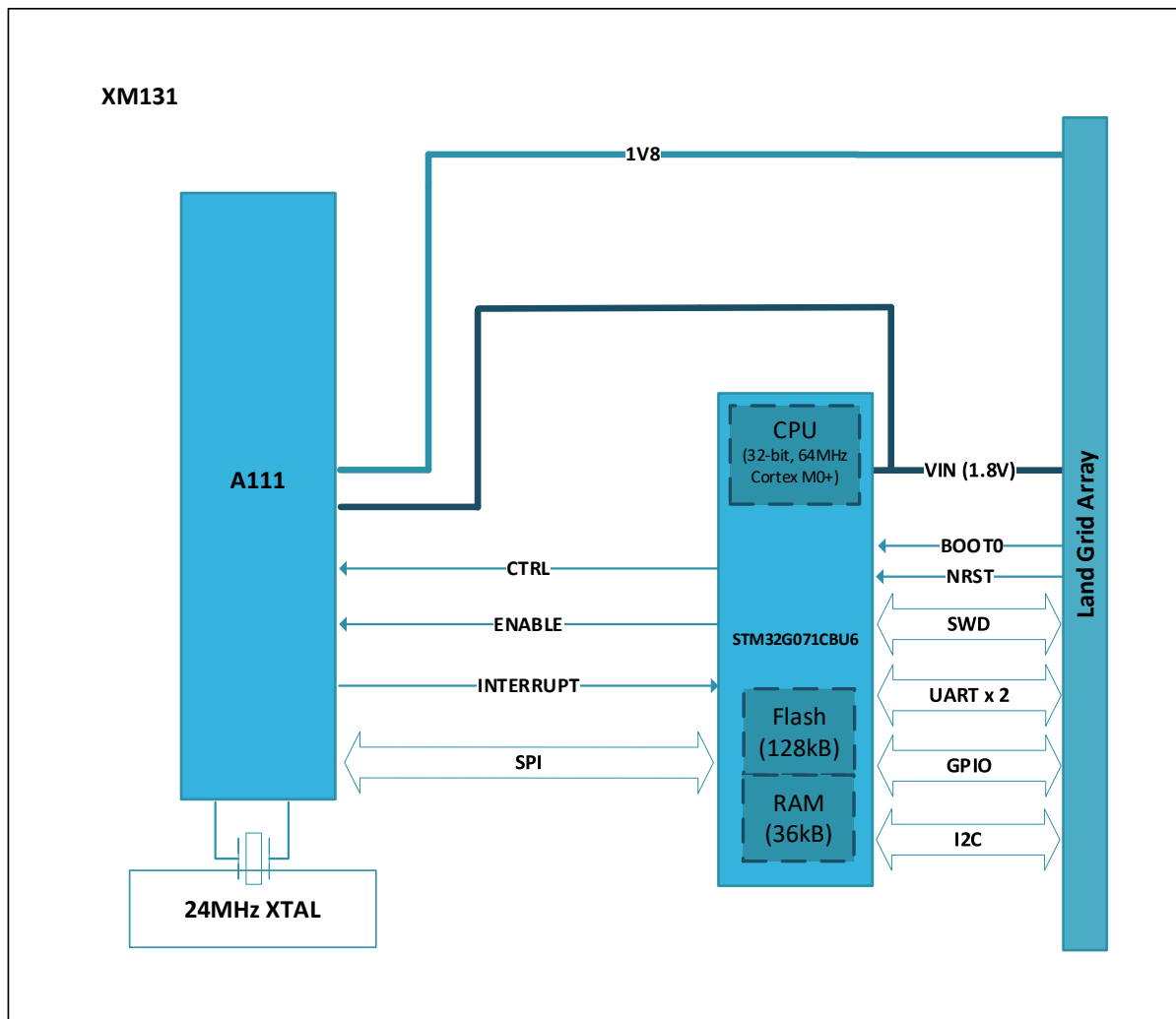

Figure 2.1. XM131 block diagram.

The XM131 block diagram shows the A111 60 GHz PCR radar connected to the M0+ microcontroller. The module provides Land Grid Arrays pads where the MCU external I/F are accessible including single voltage supply.



2.4 Module board Land Grid Array description

The LGA pads provides the external interface to the module. Figure 2.2 provides an overview of the XM131 LGA and Table 2.1 describes each signal.

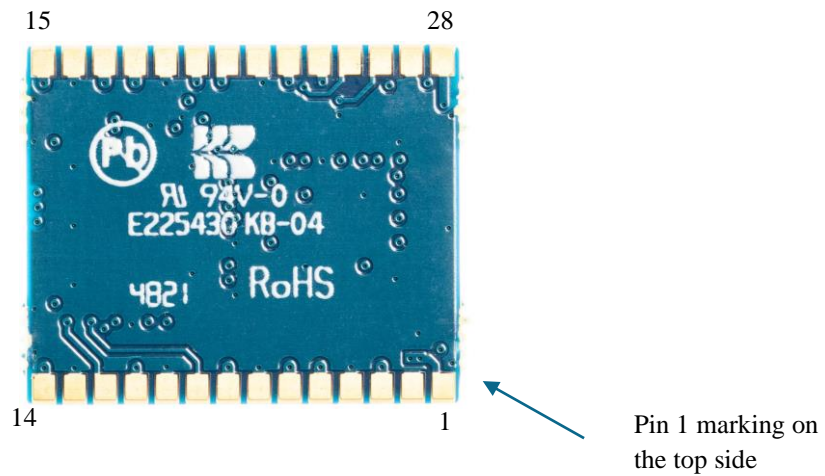

Figure 2.2. XM131 Land Grid Array.

Table 2.1. The pinning of the XM131 Land Grid Array.

Pin Number	Signal	Comment
1	VIN	1.8 V
2	Ground	
3	1V8	
4	Ground	
5	UART_TX	Connect to UART_RX on host side.
6	UART_RX	Connect to UART_TX on host side.
7	Ground	
8	UART_CTS	Connect to UART_RTS on host side.
9	UART_RTS	Connect to UART_CTS on host side.
10	Ground	
11	SWD_IO	
12	SWD_CLK_BOOT0	SWD_CLK and BOOT0 pin. Pulling BOOT0 high during boot of module will start the embedded boot loader.
13	Ground	
14	NRESET	Reset of XM131 MCU.
15	WAKE_UP	Could be used by host to wake up XM131 MCU.
16	Ground	
17	I2C_SCL	
18	I2C_SDA	



19	Ground	
20	I2C_ADDRESS	For configuration of I2C address.
21	DEBUG_UART_RX	Connect to UART_RX on host side.
22	Ground	Connect to UART_TX on host side.
23	DEBUG_UART_TX	
24	MISC_GPIO0	
25	MISC_GPIO1	
26	MISC_GPIO2	
27	Ground	Output from XM131 switched power regulator.
28	MCU_INT	Could be used to send interrupt from XM131 MCU to host.



2.5 Software options

The Entry Module XM131 can be used in two regimes:

- **Stand-alone module:** The module operates as an independent system. The application is customized to a specific use case by the customer and runs on the embedded MCU. The customer application is accessing the RSS API.
- **Controlled module:** The module is connected to an external host where the customer runs their application software. The customers are accessing the RSS API via a hardware interface through the module server, that provides register command protocol. The module output is either detector output data or service radar data through the XM131 external interfaces such as UART and I2C.

Using the Entry Module XM131 as stand-alone module Acconeer offers SDK that provides RSS, hardware abstraction layer, device drivers and build system. Based on SDK it is possible for the customer to develop their own application. Both RSS and applications runs on the embedded MCU.

Using the Entry Module XM131 as Controlled module Acconeer provides SW image including RSS and module server application that provides hardware interface accessing the RSS API through a register command protocol, see ref [3].

For further software information, see XM132 Entry Module Evaluation Kit User guide, ref [2].



3 Interfaces

3.1 Module supply input

The Entry Module XM131 support 1.8 V external single power supply, see table 4.2 recommended operating conditions. Note that supply voltage conditions (e.g. slew rate) need to be taken into consideration according to STM M0+ microcontroller datasheet, ref [5].

3.2 System functions

The XM131 module supports system power states, see XM131 Module Software User guide, Ref [3] for further information.

Module RESET is supported by activating NRST pin (active low).

Module ERASE is used to reinitialize the MCU Flash content and some of its NVM (Non-Volatile Memory) bits to an erased state. See also STM M0+ microcontroller datasheet, ref [5] for further information.

3.3 Serial interfaces

The XM131 GPIO pins can be configured to support up to two UARTs, the communication UART and a debug UART. The main UART has support for flow control. The XM131 supports up to two I2C compatible 2-wire master/slave external serial interfaces. See table 2.1 for HW configuration. See also STM M0+ microcontroller datasheet, ref [5] for further information.

The XM131 has JTAG/SWD interface for debugging and flashing. See table 2.1 for HW configuration.

3.4 I/O interfaces

The Entry Module XM131 supports three General Purpose IOs (GPIOs), MISC_GPIO0, MISC_GPIO1 and MISC_GPIO2. The GPIO pins are configurable for different functions, only the debug and RESET pins are fixed to specific GPIOs. See table 2.1 for HW configuration. See also STM M0+ microcontroller datasheet, ref [5] for further information.

The XM131 has a wake-up pin (WAKE_UP) which can be used to wake up the module.

3.5 Module reset

The XM131 has an external reset option (Pin 14 on the XM131).



4 Electrical specifications

4.1 Absolute maximum ratings

The below table shows the XM131 absolute maximum ratings over operating temperature range, unless otherwise noted:

Parameter	Description	Min.	Max.	Unit
VIN, 1V8	power supply	-0.3	2	V
I/O	Voltage on I/O pins	-0.3	2	V
T _{OP}	Operating temperature range	-40	85	°C
T _{STG}	High temperature storage		125	°C

Table 4.1. Absolute maximum ratings.

Stresses beyond those listed in table 4.1 may cause permanent damage to the device. These are stress ratings only and functional operation of the device at these conditions or at any other conditions beyond those indicated under Recommended Operating Conditions is not implied. Exposure to absolute-maximum-rated conditions for extended periods of time may affect device reliability.

4.2 Recommended operating conditions

The below table shows the XM131 recommended operating conditions:

Parameter	Min.	Typ.	Max.	Unit
VIN, 1V8 operating power supply voltage	1.71		1.89	V
I/O operating range	0		VIN+0.3	V
Operating temperature	-40		85	°C

Table 4.2. Recommended operating conditions.



4.3 Power consumption summary

The below table summarizes the XM131 power consumption, average current ratings at power terminal at $T_A = 25^\circ\text{C}$ and 1.8 V supply:

Parameter	Min.	Typ.	Max.	Unit
Measuring window: 1.0 m, 0.1 Hz update rate, sensor off		0.163 ⁽¹⁾		mW
Measuring window: 2.5 m, 20 Hz update rate, sensor hibernate		8.039 ⁽¹⁾		mW
Idle current		75 ⁽²⁾		uA

Table 4.3. Average power dissipation ratings at power terminal.

¹Configuration with Sparse service, profile 3 used.

²STM M0+ microcontroller is in sleep mode (Stop Mode 1) with full RAM retention and wake-up on RTC enabled.

4.4 RF specification

The below table shows the XM131 A111 PCR RF specification:

Parameter	Min.	Typ.	Max.	Unit
Center frequency f_c		60.5		GHz
EIRP (Equivalent Isotropically Radiated Power)			10	dBm
TX HPBW (Half Power Beam Width), elevation plane		tbd		degrees
TX HPBW (Half Power Beam Width), horizontal plane		tbd		degrees

Table 4.4. XM131 RF specification.



5 Reference design description XM131

5.1 Schematics & BOM

The following pages include the module schematics and bill of materials:



THIS DOCUMENT AND THE DATA DISCLOSED HEREIN OR
HEREWITH IS CONFIDENTIAL AND THE PROPERTY OF
ACCONEER.

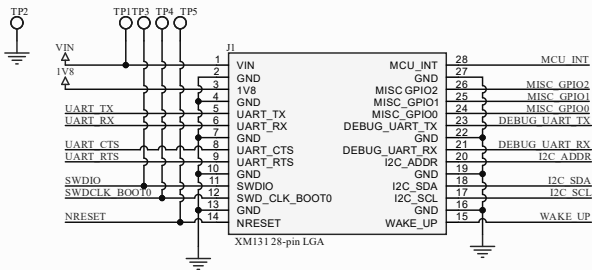
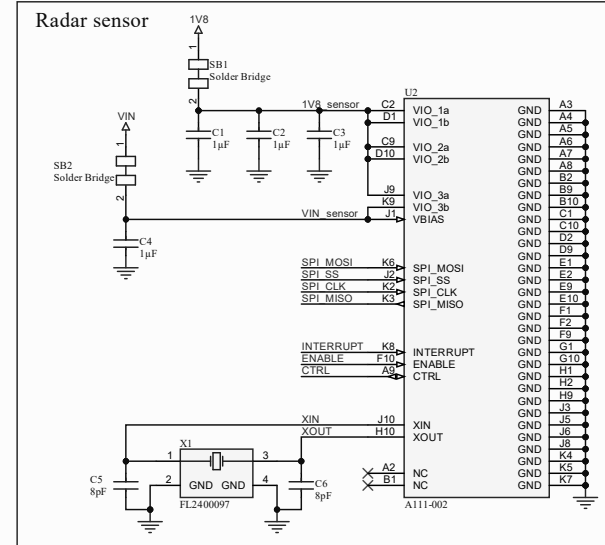
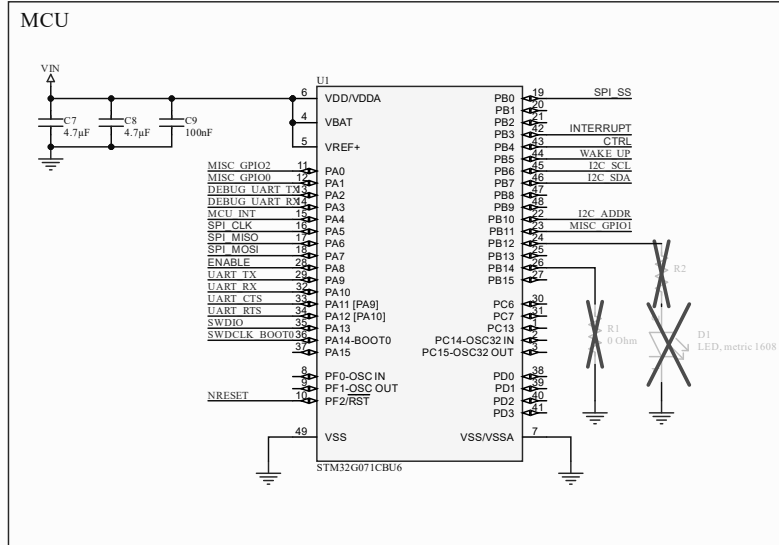

		Acconeer AB Västra Varvsgatan 19 211 77 Malmö Sweden
Title: XM131 radar module		
Size: A3	Project variant: Production	PCBA revision: R1B
Date: 2021-12-17	Sheet 1 of 1	
File: XM131_SchDoc	Drawn By: Jonas Langhacks	



Bill of Material

Table 5.1 shows the BOM for XM131.

Component Ref.	Specification	QTY	Value	Comment
C1, C2, C3, C4	Capacitor 1uF, metric 0603	4	1μF	
C5, C6	Capacitor 8pF, metric 0603	2	8pF	
C7, C8	Capacitor 4.7uF, metric 1005	2	4.7μF	
C9	Capacitor 100nF, metric 1005	1	100nF	
U1	MCU STM32G071CBU6 32-bit LQFP48	1		ST Microelectronics: STM32G071CBU6
U2	Radar Sensor 60GHz A111	1		Acconeer AB: A111
X1	Crystal 24MHz 9pF 4-Pin SMD	1	24 MHz	Diodes Incorporated: FL2400097



5.2 Component Placement Drawing

The component placement drawing of XM131 is found below:

Top side

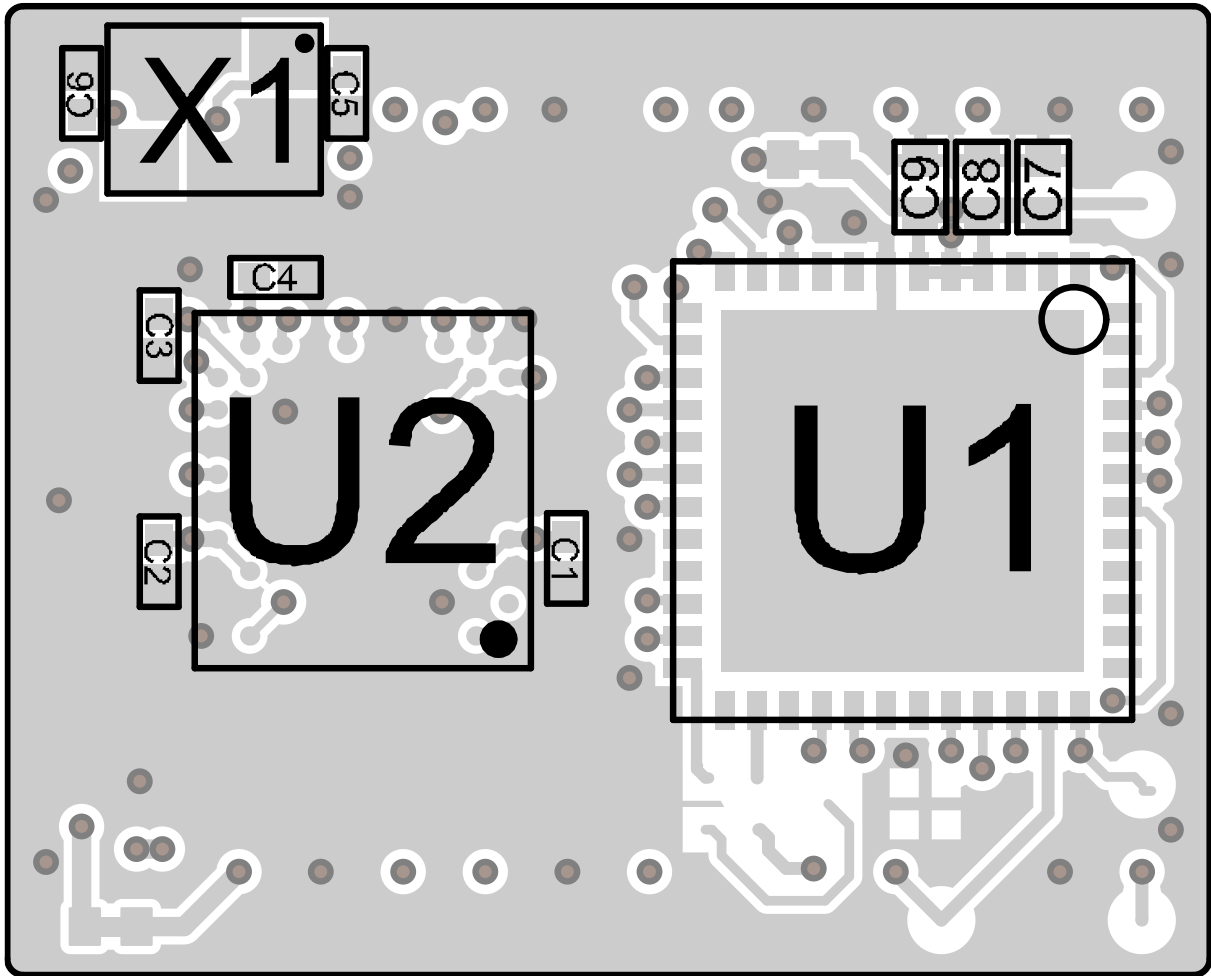

Bottom side only contains LGA pads (see Figure 2.2).



6 Mechanical specifications

XM131 Module outline – Top view and side view

Board Outline and Dimensions

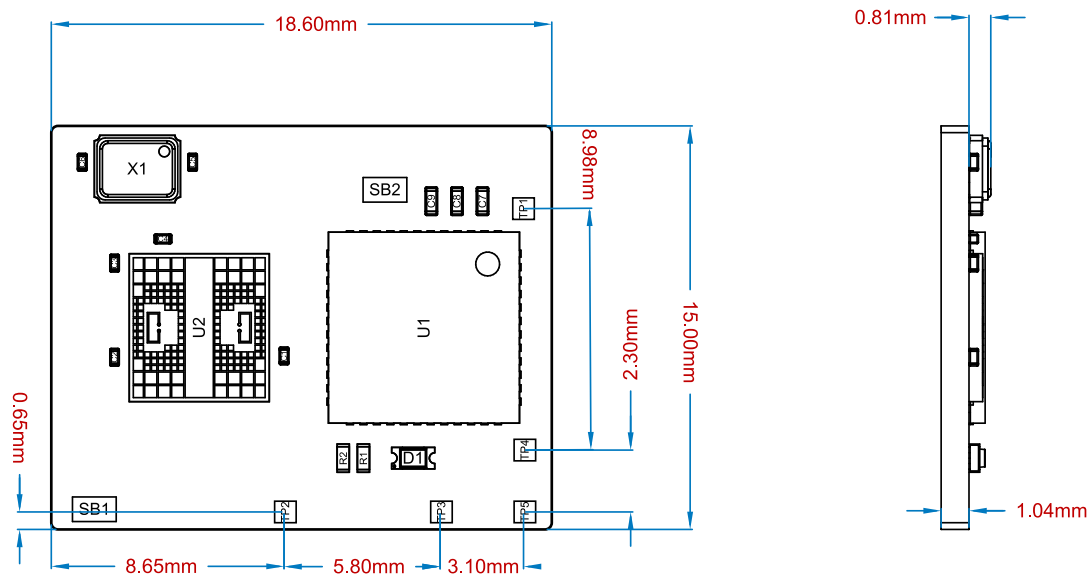



XM131 Recommended footprint

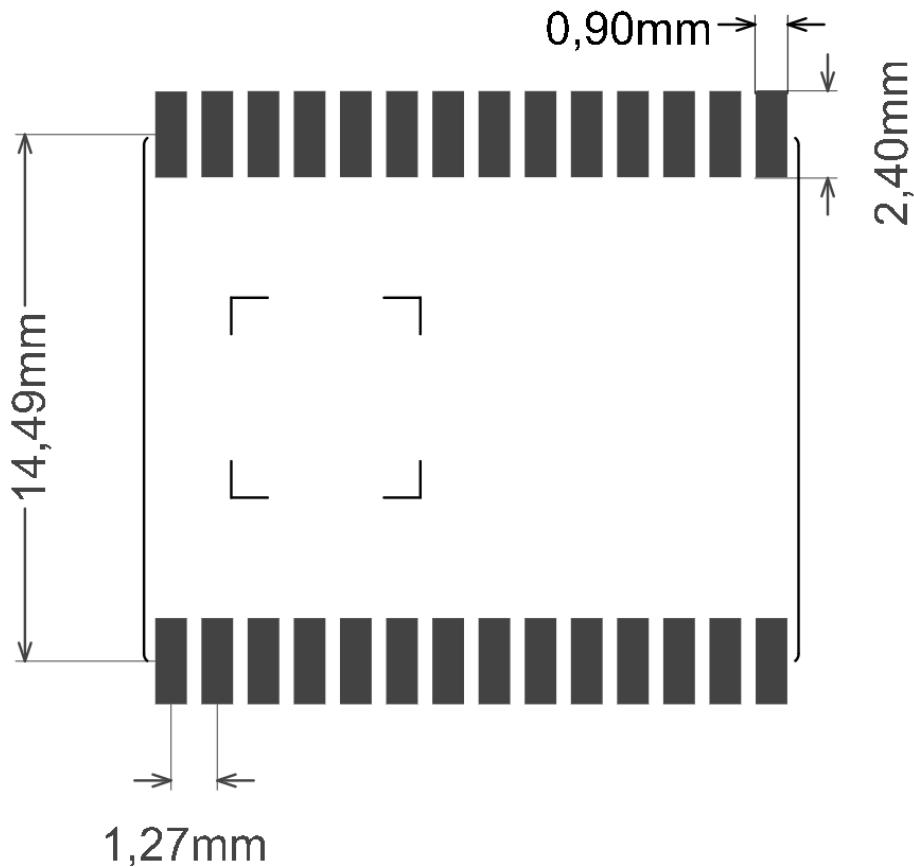

6.1 Moisture Sensitivity Level and Recommended Reflow Profile

Since XM131 contains Moisture Sensitive Devices (MSD) classified as MSL3 (A111 and MCU STM32G071C6U6), it is recommended to perform baking of the XM131 before mounting it. Refer to IPC/JEDEC J-STD-033D for details regarding baking of populated boards.

Maximum number of reflow passes recommended for XM131 is 1.

It is recommended to use a reflow profile compatible with the IPC/JEDEC J-STD-020E classification profile.

6.2 RoHS and REACH Statement

Acconeer XM131 Entry Module meet the requirements of Directive 2011/65/EC of the European Parliament and of the Council on the Restriction of Hazardous Substances (RoHS) and the requirements of the REACH regulation (EC 1907/2006) on Registration, Evaluation, Authorization and Restriction of Chemicals.



7 Reference documents

- [1] A111 Pulsed Coherent Radar (PCR) Datasheet:
<https://developer.acconeer.com/>
- [2] XM132 Entry Module Evaluation Kit, User guide
<https://developer.acconeer.com/>
- [3] XM131 Module Software User guide
<https://developer.acconeer.com/>
- [4] XE132 IoT Evaluation board, Product brief
<https://developer.acconeer.com/>
- [5] MCU STM32G071CUB6 Datasheet:
[STM Semiconductor](https://www.st.com/en/microcontrollers/stm32g071cub6.html)
- [6] Hardware and physical integration guideline
<https://developer.acconeer.com/>



8 Abbreviations

AiP	Antenna in Package
API	Application Programming Interface
BOM	Bill of Materials
EIRP	Equivalent Isotropically Radiated Power
GND	Ground
GPIO	General Purpose Input/Output
HPBW	Half Power Beamwidth
HW	HardWare
I2C	Inter-Integrated Circuit
LGA	Land Grid Array
MCU	MicroController Unit
NVM	Non-Volatile Memory
PCR	Pulse Coherent Radar
RF	Radio Frequency
RSS	Radar System Software
SDK	Software Development Kit
SoC	System on Chip
SPI	Serial Peripheral Interface
SW	SoftWare
SWD	Serial Wire Debug
UART	Universal Asynchronous Receiver/Transmitter



Disclaimer

The information herein is believed to be correct as of the date issued. Acconeer AB (“**Acconeer**”) will not be responsible for damages of any nature resulting from the use or reliance upon the information contained herein. Acconeer makes no warranties, expressed or implied, of merchantability or fitness for a particular purpose or course of performance or usage of trade. Therefore, it is the user’s responsibility to thoroughly test the product in their particular application to determine its performance, efficacy and safety. Users should obtain the latest relevant information before placing orders.

Unless Acconeer has explicitly designated an individual Acconeer product as meeting the requirement of a particular industry standard, Acconeer is not responsible for any failure to meet such industry standard requirements.

Unless explicitly stated herein this document Acconeer has not performed any regulatory conformity test. It is the user’s responsibility to assure that necessary regulatory conditions are met and approvals have been obtained when using the product. Regardless of whether the product has passed any conformity test, this document does not constitute any regulatory approval of the user’s product or application using Acconeer’s product.

Nothing contained herein is to be considered as permission or a recommendation to infringe any patent or any other intellectual property right. No license, express or implied, to any intellectual property right is granted by Acconeer herein.

Acconeer reserves the right to at any time correct, change, amend, enhance, modify, and improve this document and/or Acconeer products without notice.

This document supersedes and replaces all information supplied prior to the publication hereof.

© 2022 by Acconeer – All rights reserved



Acconeer AB
Västra Varvsgatan 19
211 77 MALMÖ
Sweden

www.acconeer.com
info@acconeer.com
+46 10 218 92 00